



User Manual

R1 PLUS

Total Station





Dear Customer:

Congratulations! We, STONEX, are proud to present you with these series instrument. Your total station is a rugged and reliable instrument whose performance and design are not surpassed.

To fully appreciate and protect your investment, we suggest that you take the necessary time to read and fully understand this manual. We have a dedicated service organization. If the need arises, please don't hesitate to contact us.

Thank you for your trust and confidence.

Contents

1. Precautions for Safety.....	5
1.1 Note.....	5
1.2 Definition of Indication.....	6
1.3 Safety Standards for Laser (R1 series)	7
1.4 About User.....	8
1.5 Exceptions from Responsibility.....	8
2. Preparation before Measurement.....	9
2.1 About Battery.....	9
2.1.1 Battery Power Symbol	9
2.1.2 Replace the Battery	10
2.1.3 Recharge the Battery	10
2.2 Setting up the Instrument	11
2.3 Centering and Levelling-Up.....	11
2.4 Accurate Levelling-Up with Electronic Level on screen.....	12
3. Basic Functions	13
3.1 Nomenclature.....	13
3.2 Basic Key Operation.....	15
3.3 Display.....	16
3.4 Mode Diagram	17
3.5 Power On/Off.....	19
3.6 Registration & Demo Mode	20
3.7 How to Input Number and Alphabet.....	21
3.8 How to Configure.....	22
3.9 How to Set Parameters.....	24
3.9.1 Measure Condition Setting.....	24
3.9.2 Instrument Basic Setting.....	26
3.9.3 Communication Port Setting.....	27
3.9.4 Unit Setting	28
3.9.5 Date & Time Setting	29
3.9.6 Key Function Setting.....	29
3.9.7 EDM Setting.....	31
4. Angle Measurement.....	33
4.1 Measure a Horizontal Angle of Two Points.....	33
4.2 Set the Horizontal Angle to a Required Value.....	34
5. Distance Measurement	35

6. Coordinate Measurement	37
6.1 Input the Occupied Point Data	37
6.2 Azimuth Setting	39
6.3 3D Coordinate Measurement	40
7. Stake out Measurement	42
7.1 Distance Stake out	42
7.2 Coordinates Stake out Measurement	44
7.3 REM Stake out Measurement	46
8. Area	47
8.1 Area Calculation by Measured Data	48
8.2 Area Calculation by Reading Existed Coordinates	49
9. Offset Measurement	50
9.1 Single-distance Offset Measurement	50
9.2 Angle Offset Measurement	52
9.3 Dual-Distance Offset Measurement	53
10. MLM	55
10.1 Measuring Distance between Two or More Points	55
10.2 Change the Starting Point	56
11. REM	57
12. Resection	58
12.1 Coordinate Resection	59
12.2 Elevation Resection	60
12.3 Resection Calculation Process	62
12.4 Precautions When Performing Resection	63
13. Point Projection	64
13.1 Define Baseline	64
13.2 Point Projection	66
14. Stake out Line	67
14.1 Define Baseline	67
14.2 Stake Out Line-Point	68
14.3 Stake out Line/Line	69
15. Traverse Surveying	71
15.1 Save Coordinate	71
15.2 Read Coordinate	72
16. Inverse	73
17. Polar Coordinates Calculation	74
18. Repetition Angle Measurement	76

19. Arc Staking Out Measurement.....	78
19.1 Occ. Orientation	78
19.2 2pt+Radius Arc Staking Out.....	79
19.3 Three Point Arc Staking Out.....	85
20. Road Staking Out Measurement.....	87
20.1 Input the Start Station	88
20.2 Input Road Horizontal Elements	88
20.2.1 Input Line Element	88
20.2.2 Input Circle Element	89
20.2.3 Input Spiral Element	90
20.2.4 Road Horizontal Element Editing	90
20.3 Input Road Vertical Elements	92
20.3.1 Input Vertical Road Element.....	92
20.3.2 Edit Vertical Road Element	93
20.4 Road Calculation	95
20.4.1 Input the road width element	95
20.4.2 Additional Station Setting	96
20.4.3 Road Calculation	97
20.5 Road Staking Out Data View	98
20.6 Road Stake Out.....	99
20.7 Road File Management.....	100
20.7.1 Select a Road File.....	100
20.7.2 Rename a Road File.....	101
20.7.3 Delete a Road File.....	102
20.7.4 Delete all Road Files.....	103
21. Record	104
21.1 Record Occupied Data	104
21.2 Collect Angle Data.....	106
21.3 Collect Points.....	106
21.4 Record Note.....	107
21.5 View Data.....	109
21.6 Select job	110
22. JOB Management.....	111
22.1 Storage Media Select.....	111
22.2 Select a JOB.....	112
22.3 Rename a JOB	113
22.4 Delete a JOB.....	113

22.5 Output JOB Data	115
22.6 File Copy	116
22.7 Connect PC via USB port	117
23. Known Data Management.....	118
23.1 Input Known Point Coordinate by Keys.....	118
23.2 Input Known Point Coordinate via RS-232C.....	119
23.3 Delete known point coordinate	120
23.4 View known points data	121
23.5 Clear all known points' data	122
24. Code Management.....	123
24.1 Edit Code list.....	123
24.2 Clear all Codes	124
25. Warning and Error Messages	125
26. Check and Adjustment.....	126
26.1 The Instrument Constant.....	126
26.2 Tubular Level	127
26.3 Circular Level	127
26.4 The Optical Sight.....	128
26.5 Optical Plummet (optional)	128
26.6 Laser Plummet	129
26.7 Vertical Cross-hair on Telescope	129
26.8 Horizontal Collimation Error C	130
26.9 Tilt Sensor	131
26.10 Vertical Index Error.....	132
26.11 EDM Optical Axis and the Telescope Sighting Axis Error	134
27. Technical Data.....	136
28. Accessories	140
Appendix I: Atmospheric correction formula and chart (Just for reference)	141
Appendix II: Correction for refraction and earth curvature.....	143
Appendix III: STANDARD LIMITED WARRANTY	144
General Warranty for Instruments.	144
Shipping policy.....	144
Return policy Dead On Arrival instruments.....	145
Over Warranty repair(s) policy.	145
Disclaimer and Limitation of Remedy.....	145
Appendix IV: FCC Statements	148
Appendix V: Environmental recycling	149

1. Precautions for Safety

1.1 Note

Don't collimate the sun directly

Avoid insulating the instrument, and don't collimate the sun directly for protecting eyes and instrument.

Avoid the librations on the instrument

When transporting, keep the instrument in the case and try your best to lighten librations.

Carry the instrument

When carrying, the instrument handle must be hold tight.

Check the battery power

Before using it, you should check the power whether it is enough.

Battery maintenance

If the instrument is not used for a long time, the battery should be taken out from the instrument and stored in separate place. Meantime, the battery should be charged every month.

Take out the battery

It is not suggested to take out the battery when the instrument is on, otherwise, the stored data may be lost, so it is better to replace the battery after power off the instrument.

Set up the instrument on the tripod

When using it please insure the connection between tripod and instrument is firm. It is better to work with wooden tripod for the measurement accuracy.

Assemble the tribrach on the instrument

The setting of tribrach would influence the accuracy. The tribrach should be check frequently, the screw which connects the tribrach and alidade must be locked tightly. And the central fixing screw should be tight.

High temperature condition

Don't put the instrument in high temperature condition for a long time, it is bad for the instrument performance.

Temperature changing sharply

The sharp temperature changing on the instrument or prism will shorten the distance measurement range, for example, after taking the instrument out from a warm car to a cold condition, wait for some time, it can be used when it adapts the surrounding condition.

The noise from the instrument

When the instrument working, it is normal if you hear the noise from instrument motor, it will not affect the instrument work.



Stored data responsibility

STONEX should not be held liable for the lost data because of wrong operation.

1.2 Definition of Indication

For the safe of your product and prevention of injury to operators and other persons as well as prevention of property damage, items which should be observed are indicated by an exclamation point within a triangle used with WARNING and CAUTION statements in this manual.

The definitions of the indication are listed below. Be sure you understand them before reading the manual's main text.

	WARNING:	Ignoring this indication and making an operation error could possibly result in death or serious injury to the operator.
	CAUTION:	Ignoring this indication and making an operation error could possibly result in personal injury or property damage.

WARNING

- Do not perform disassembly or rebuilding. Fire, electric shock or burns could result.
Only STONEX authorized distributors can disassemble or rebuilt.
- Do not collimate the sun directly. The eye injury or blind could result.
- Do not cover the charger. Fire could be result.
- Do not use defection power cable, socket or plug. Fire, electronic shock could result.
- Do not use wet battery or charger. Fire, electronic shock could result.
- Do not close the instrument to burning gas or liquid, and do not use the instrument in coal mine. Blast could be result.
- Do not put the battery in the fire or high temperature condition. Explosion, damage could result.
- Do not use the battery which is not specified by STONEX. Fire, electric shock or burn could result.
- Do not use the power cable which is not specified by STONEX. Fire could result.
- Do not short circuit of the battery. Fire could result.
- When this product encounters disturbance of severe Electrostatic Discharge, perhaps it will have some degradation of performance like switching on/off automatically and so on.



CAUTION

- Do not touch the instrument with wet hand. Electric shock could result.
- Do not stand or seat on the carrying case, and do not turn over the carrying case arbitrarily, the instrument could be damaged.
- Be careful of the tripod tiptoe when setup or move it.
- Do not drop the instrument or the carrying case, and do not use defective belt, agraffe or hinge. Instrument damage could result.
- Do not touch liquid leaking from the instrument or battery. Harmful chemicals could cause burn or blisters.
- Please assemble the tribrach carefully, if the tribrach is not stable, series damage could result.
- Do not drop the instrument or tripod, series damage could result. Before use it, check the central screw is tight.

1.3 Safety Standards for Laser (R1 series)

R1 series adopt the class of Laser Product according to IEC Standard Publication 60825-1 Amd. 2:2001. According this standard, EDM device is classified as Class 3R Laser Product when reflectless measurement is selected, when the prism and reflective sheet is selected as target, the output is equivalent to the safer class 1. Follow the safety instructions on the labels to ensure safe use.

CAUTION: CLASS 3R LASER RADIATION WHEN OPEN

AVOID DIRECT EYE EXPOSURE.

CAUTION: CLASS 2 LASER RADIATION WHEN OPEN

DO NOT STARE INTO THE BEAM



Note for Safety



WARNING

- Never point the laser beam at other's eyes, it could cause serious injury.
- Never look directly into the laser beam source, it could cause permanent eye damage.
- Never stare at the laser beam, it could cause permanent eye damage.
- Never look at the laser beam through a telescope or other optical devices, it could cause permanent eye damage.

1.4 About User

1) This product is for professional use only!

The user is required to be a qualified surveyor or have a good knowledge of surveying, in order to understand the user manual and safety instructions, before operating, inspecting or adjusting.

2) Wear required protectors (safety shoes, helmet, etc.) when operating.

1.5 Exceptions from Responsibility

1) The user of this products is expected to follow all operating instructions and make periodic checks of the product's performance.

2) The manufacturer, assumes no responsibility for results of a faulty or intentional usage or misuse including any direct, indirect, consequential damage, and loss of profits.

3) The manufacturer, assumes no responsibility for consequential damage, and loss of profits by any disaster, (an earthquake, storms, floods etc.).

4) The manufacturer, assumes no responsibility for any damage, and loss of profits due to a change of data, loss of data, an interruption of business etc., caused by using the product or an unusable product.

5) The manufacturer, assumes no responsibility for any damage, and loss of profits caused by usage except for explained in the user manual.

6) The manufacturer, assumes no responsibility for damage caused by wrong transport, or action due to connecting with other products.

2. Preparation before Measurement

2.1 About Battery

2.1.1 Battery Power Symbol

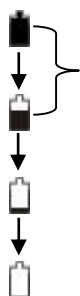

Measurement is possible

The battery is lower, it is better to replace or recharge it

Measurement is impossible, it is necessary to replace or recharge battery

NOTE:

- The working time of battery will be effected by many factors, such as ambient temperature, recharging time, recharging and discharging times. On the data safe side, we suggest the users recharge the battery full or prepare several full batteries before operation.
- The battery symbol only indicates power capability for current measurement mode. The power consumption in distance measurement mode is more than in angle mode, if the instrument enters into distance measurement mode from angle mode, the power maybe auto-off because of lower battery.
- The symbol only indicates the supply power but not the instantaneous power change. And if the measurement mode changes, the symbol will not show the power's decrease or increase immediately.
- It is suggested to check every battery power before field work.

2.1.2 Replace the Battery



1) Remove the battery

- ① Press the button downward as shown left
- ② Remove the battery by pulling it toward you

2) Mount the battery

- ① Insert the battery to the instrument
- ② Press the top of the battery until you hear a Click.

2.1.3 Recharge the Battery



As above figures show, connect the charger and the battery, then plug the charger into the outlet of 100V-240V AC power supply, recharging will begin.

NOTE:

- For a new (or long time no use) battery, in order to fully extend its capacity, it is absolutely necessary to carry out 3 to 5 complete charging/discharging cycles, and the charging time must be 10 hours at least each time.
- The indicator light on the charger will illuminate three separate colors for varies mode conditions:
 - Solid Red Light — indicates that the charger is working;
 - Solid Green Light — indicates that the charge has finished;
 - Flashing Red Light — indicates no battery on charging, poor connection or some problems exist.
- It is recommended to continue charging for 1 or 2 hours after the light turn green.
- Once the red light flashes constantly after the charger is plugged into the outlet of 100V-240V AC power supply, please remove the battery and reconnected it after 3 or 5 min.

2.2 Setting up the Instrument

Mount the battery in the instrument before performing this operation because the instrument will tilt slightly if the battery is mounted after leveling.

- I. Set up the tripod first: extend the extension legs to suitable lengths and tighten the screws on the midsections. Make sure the legs are spaced at equal intervals and the head is approximately level. Set the tripod so that the head is positioned over the surveying point. Make sure the tripod shoes are firmly fixed in the ground.
- II. Mount the instrument on the tripod head. Supporting it with one hand, tighten the centering screw on the bottom of the unit to make sure it is secured to the tripod.

2.3 Centering and Levelling-Up

1. Position tripod legs so that the plummet is aimed to the ground mark point. Turn the focusing ring of the optical plummet to focus.
2. Turn three footscrews of the tribrach till the center of reticle exactly coincides with the surveying point in any position.
3. Move the tripod legs to center the circular level. The instrument is now roughly leveled-up.
4. Center the bubble in the circular level

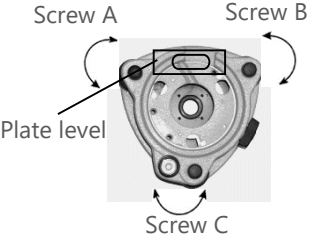
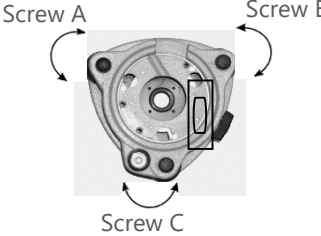
	<p>Loosen the horizontal motion clamp, and turn the instrument till the plate level is parallel to a line shaped with screws A and B. Adjust the screws A and B to make the bubble in the center of the level.</p>
	<p>Turn the instrument approximately 90°. Adjust screw C, till the bubble in the center of the level.</p>
<p>Repeat above steps until the bubble remains in the center of the plate level while the instrument is rotated to any position.</p>	

5. Center the surveying point again.

Loosen the centering screw slightly. Looking through the optical plummet eyepiece, slide the instrument over the tripod head until the surveying point is exactly centered in the reticle. Re-tighten the centering screw securely.

6. Check again to make sure the bubble in the plate level is centered.

If not, repeat procedure 4.

2.4 Accurate Levelling-Up with Electronic Level on screen

It is convenient for R1 series to level-up with electronic level, especially when it is difficult to observe the circular level and plate level.

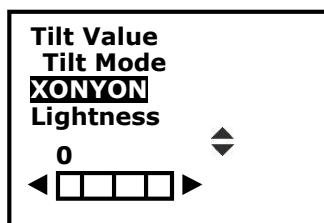

1. Power on the instrument and press key {BS} directly, and the electric level displays on screen.

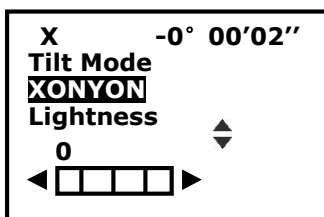

2. Level it by turning three foot screws, see above operation "3. Center the bubble in the plate level".

NOTE:

1. On this menu you can turn on/off the X/Y compensator by pressing ▲ or ▼ key.
2. If the instrument is equipped with laser plummet, after opening this menu, the laser plummet adjusting bar will display. With pressing ◀ or ▶ key the laser lightness can be adjusted.

3. Basic Functions

3.1 Nomenclature





3.2 Basic Key Operation



Keys	Description
F1~F4	Select the functions matching the softkeys
0~9	1.Input number when numeric input 2.Input characters when alphabetic input
•	Input a decimal point
±	Input plus/minus sign
Power	Power on/off
★	Enter into setting mode directly
ESC	Escape to the previous menu or mode
SFT	1. Shift between number and alphabetic when inputting 2.Shift targets model when measuring
BS	1. Delete the character at the left of the cursor when inputting 2. Open electronic level menu
Space	1. Input a black space when inputting 2. Input the target or instrument height
Func	Turn page
ENT	1. Select/Accept input data 2. Accept the option when selecting

3.3 Display

The LCD could display 6 lines with 20 characters per line. In measurement mode, it displays some common information in above 5 lines and displays soft functions in the last line.

Status screen

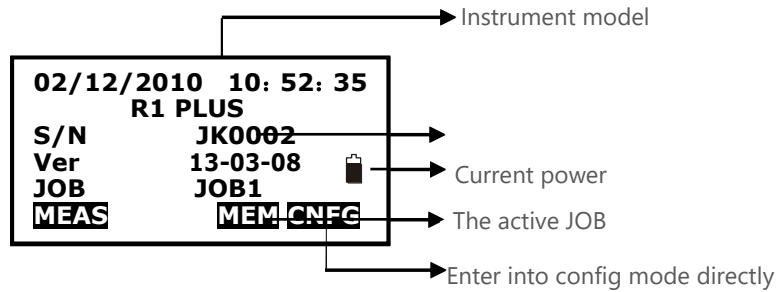

Basic measure mode

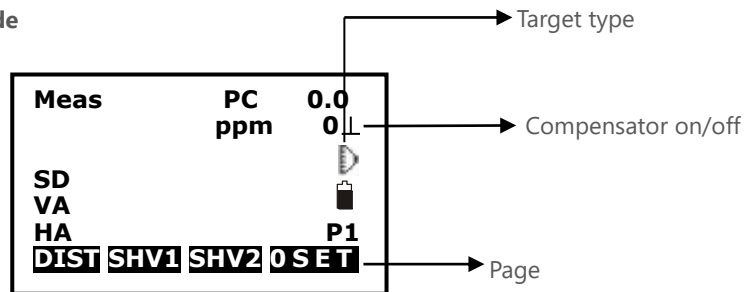

Measuring

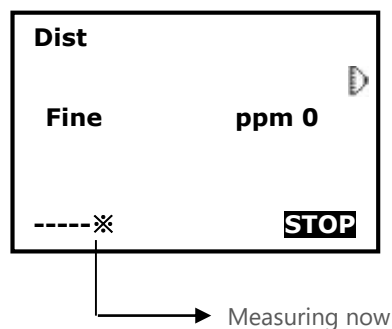

3.4 Mode Diagram

Meas mode

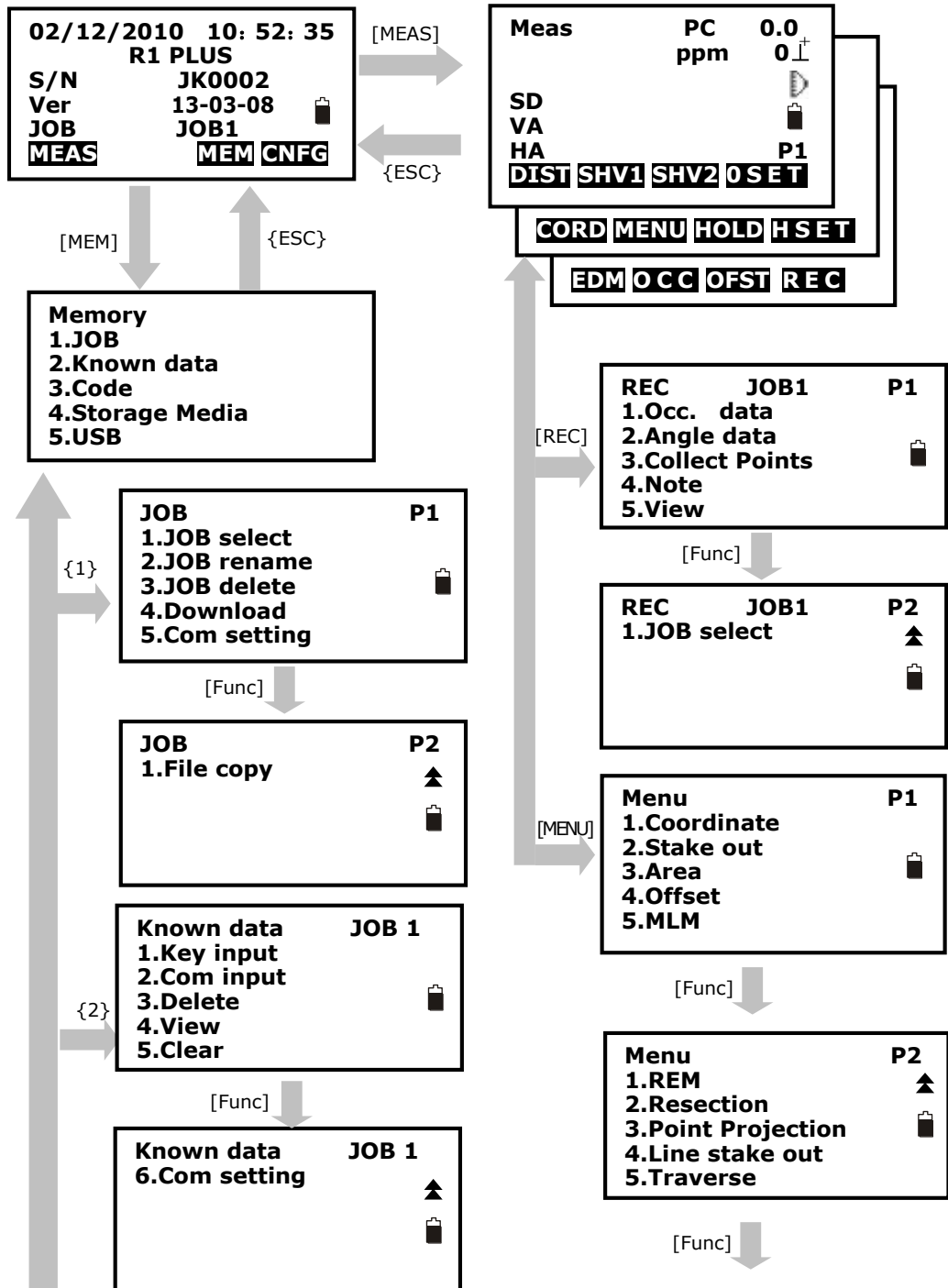

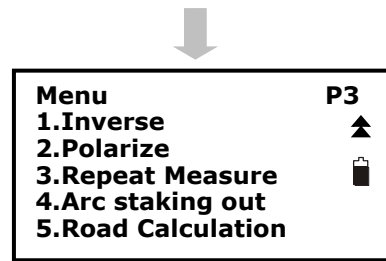
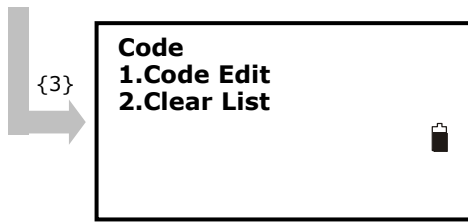

Cnfg mode

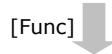
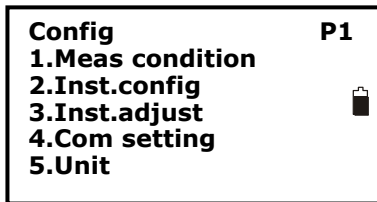
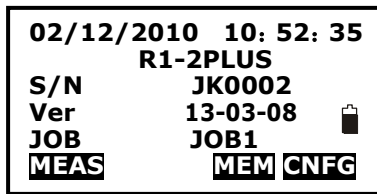

Setting mode (Press {★} directly)

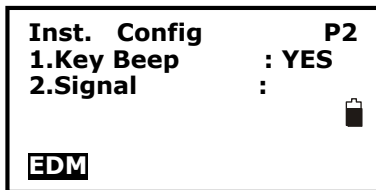
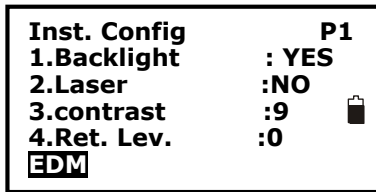

3.5 Power On/Off

I. Power on



1. Confirm the instrument is leveling, press the red key {POWER}, then press the key {skip}.

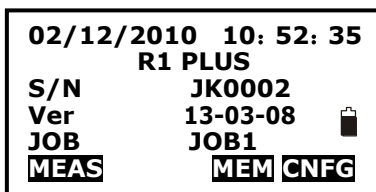

2. The instrument will power on and display the status screen.

II. Power off

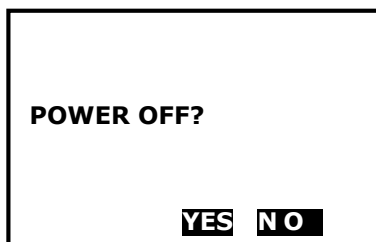

Press {POWER} key, the instrument will ask you to turn off the instrument or not, press F3(Yes), it will be turned off, press F4(No) back to previous screen.

3.6 Registration & Demo Mode

When you start R1 for the first time you will see the registration screen.

To activate R1 program you need to call Stonex local dealer, or email us the instrument serial number.

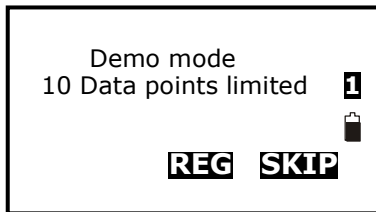

We will then issue you a registration number that you can enter in the No. field. Press F3(REG) key to program registering screen, when you enter the registration number you will see the words "Success" and the program will run in registered mode.

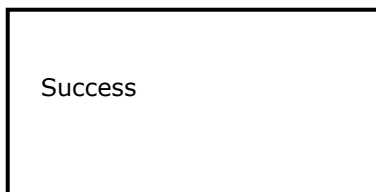
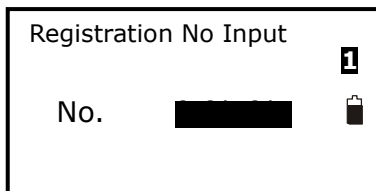

If you have no the registration number, you can press F4 (SKIP) to run R1 in demo mode.

In Demo mode the program is limited to taking only 10 points.

3.7 How to Input Number and Alphabet

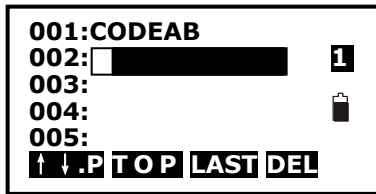

1. Enter into input code status (See§21.1 Input a code), the cursor is blinking and ready to input. The note “A” at the top right corner shows the active input mode, you can press the key {shift} to switch between alphabet and number.

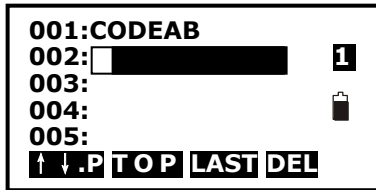

2. Input the code in turn and press the blue key {ENT} to save it. You can press key {BS} to delete your wrong input before the cursor. The max length of a code is 16 characters.

3.8 How to Configure

Inst. Config		P1
1.Backlight	: YES	
2.Laser	: NO	
3.contrast	: 9	
4.Ret. Lev.	: 0	
EDM		

Press key {★} on panel directly to enter into in any status, and do some basic settings.

1. Backlight

Press numeric key {1}, then press left key {◀} or right key {▶} to turn on or not.

Inst. Config		P1
1.Backlight	: YES	
2.Laser	: NO	
3.contrast	: 9	
4.Ret. Lev.	: 0	
EDM		

2. Laser

Press numeric key {2}, then press left key {◀} or right key {▶} to turn no/off laser beam for pointing target.

Inst. Config		P1
1.Backlight	: YES	
2.Laser	: NO	
3.contrast	: 9	
4.Ret. Lev.	: 0	
EDM		

3. contrast

Press numeric key {3}, then press left key {◀} or right key {▶} to adjust LCD display contrast.

Inst. Config		P1
1.Backlight	: YES	
2.Laser	: NO	
3.contrast	: 9	
4.Ret. Lev.	: 0	
EDM		

4. Ret. Lev.

Press numeric key {4}, then press left key {◀} or right key {▶} to telescope illumination on reticle. If the value is zero, the illumination is turned off.

EDM		P1
Mode	: Fine "s"	
Reflector	: NoPrism	
Pri. const	: 0.0	

5. EDM setting menu

Press function key {F1} to open the EDM setting menu.

EDM		P2
Temp	: 20°C	
Pressure	: 760mmHg	
ppm	: 0	
OPPM		

Press Func key to turn to page 2.

Press Func key to turn to page 2 of Star Configure menu

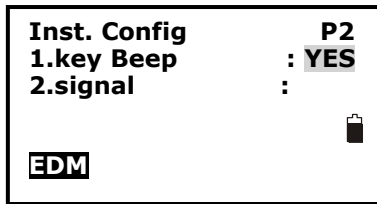

1. Key beep

Press numeric key {5}, then press left key {◀} or right key {▶} to turn on key beep or not, if you select NO, you will not hear the beep voice when press any key.

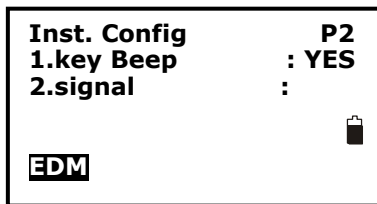

2. Signal

Aim at a target, then press numeric key {3} and the instrument will beep, the EDM returned signal value will display simultaneously.

3.9 How to Set Parameters

Press key {F4} on the keyboard to enter into config mode in any status, all the following items can be set.

3.9.1 Measure Condition Setting

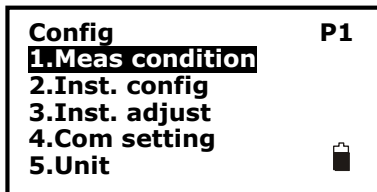

1. Press key {F4} to enter into config mode.

2. Select "1.Meas condition" to set measurement parameters. All items display on two pages.

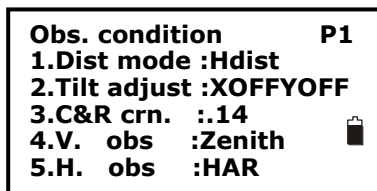

3. Change the settings if necessary. Press keys {▲}/ {▼} to select items and press keys {◀}/ {▶} to set options.

4. Press Func key to turn to page 2.

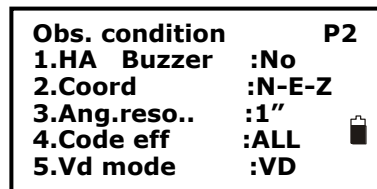

5. Press Func key to turn to page 3.

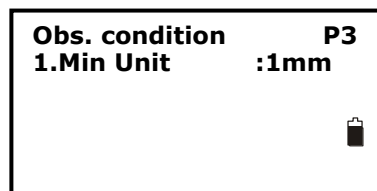

6. Press key {ESC} back to the previous mode.

Table 3-1 List of measurement condition setting

Item	Options
1.Dist Mode	SD * /HD/VD
2.Tilt Mode	XonYon * /XonYoff/XoffYoff
3.C&R crn	.14 * /.20/No
4.V. obs	Zenith * /VA/V90
5.H. obs	HAR * /HAL
1.HA Buzzer	No * /Yes
2.Coord	N-E-Z * /E-N-Z
3.Ang .reso	1" * /5" /10" ; 0.0002g * /0.001g/0.002g; 0.005mil * /0.02mil/0.05mil
4.Code eff	The manual input code is available once or always
5.Vd mode	Display mode of vertical distance: to instrument center or to the ground
1.Min Unit	According to the minimum unit

NOTE:

Every first options with the symbol " * " are the factory setting.

3.9.2 Instrument Basic Setting

Config	P1
1.Meas condition	
2.Inst. config	
3.Inst. adjust	
4.Com setting	
5.Unit	

1. Press key {F4} to enter into config mode.

2. Select "2.Inst. config" to set instrument basic parameters. Three items display.

Inst config	:15min
1.Power off	:9
2.LCD cont.	:7
3.Ret level	
	

3. Change the settings if necessary. Press keys {▲}/ {▼} to select items and press keys {◀}/ {▶} to set the options.

4. Press key {ESC} back to the previous mode.

Table 3-2 Option list of basic setting

Item	Options
1. Power off	30min * /No/5min/10min/15min (The instrument would power off automatically to save battery if no operation in setting time)
2.LCD cont.	0~13 (9 *)
3.Ret level	0~9 (7 *)

NOTE:

The options with the symbol " * " are the factory setting.

3.9.3 Communication Port Setting

Please set communication parameters before connecting your computer.

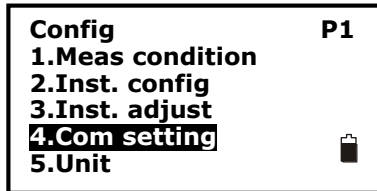

1. Press key {F4} to enter into config mode.

2. Select **"4. Com setting"** to set the parameters of communication port.

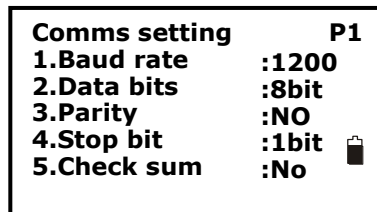

3. Change the settings if necessary. Press keys {▲}/ {▼} to select items and press keys {◀}/ {▶} to set the options.

4. Press Func key to turn to page 2.

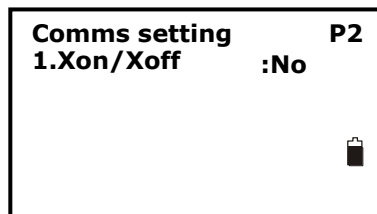

5. Press key {ESC} back to the previous mode.

Table 3-3 Option list of com setting

Item	Options
1.Baud rate	1200 * /2400/4800/9600/19200/38400
2.Data bits	8bit * / 7 bit
3.Parity	No * / Even/ Odd
4.Stop bit	1bit * / 2bit
5.Check sum	No * / Yes
1.Xon/Xoff	No * / Yes

NOTE:

Every first options with the symbol " * " are the factory setting.

3.9.4 Unit Setting

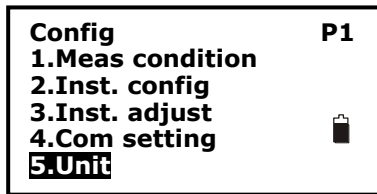

1. Press key {F4} to enter into config mode.

2. Select "5.Unit" to set unit.

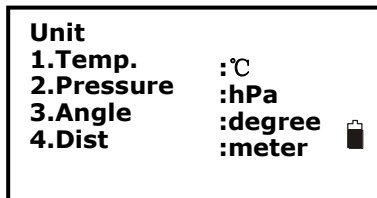

3. Change the settings if necessary. Press keys {▲}/ {▼} to select items and press keys {◀} / {▶} to set the options.

4. Press key {ESC} back to the previous mode.

Table 3-4 Option list of unit setting

Item	Options
1. Temp.	°C * / °F
2.Pressure	hPa * / mmHg / inchHg/mbar/psi
3.Angle	degree * / gon / mil
4.Dist	meter * / Us-feet/Int-ft

NOTE:

Every first options with the symbol " * " are the factory setting.

3.9.5 Date & Time Setting

The date and time displays at the status mode.

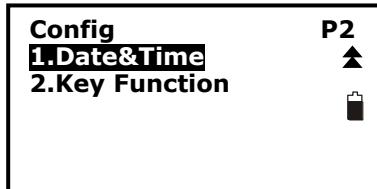

1. Press key {F4} to enter into config mode.

2. Select "1. Date & Time".

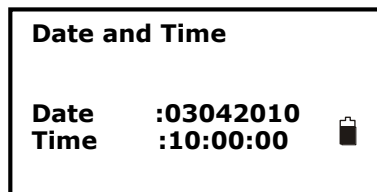

3. Input date and time. The date format: month/date/year.

4. Press key {ENT} to save settings and back to the previous mode.

3.9.6 Key Function Setting

1. Press key {F4} to enter into config mode.



2. Select "2. Key Function".

3. Press key {1} to enter **Key Set** menu

4. Press key {2} to enter **Key Save** menu

5. Press key {3} to enter **Key Resume** menu

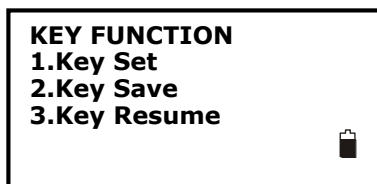

Key Set: the soft key's function at basic measurement mode can be changed.

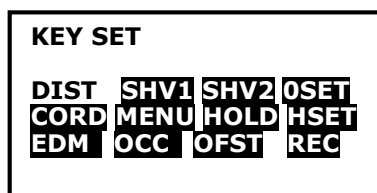

1. Move the cursor to the key, change the key's function according to your need by pressing keys {▲}/{▼} to select.

2. Press Key {F4} to confirm the key defined

Following items can be defined:

Items	Descriptions
DIST	Start distance measure
SHV1	Display switching between SD/HAVA, HD/HA/VA and VD/HA/VA
SHV2	Display switching between SD/HD/VD and SD/HA/VA
0SET	Set horizontal angle to 0
CORD	Enter coordinate measurement menu
MENU	Enter program menu
HOLD	Hold the horizontal angle
HSET	Set horizontal angle
EDM	Enter distance setting menu
OCC	Setting the station point
OFST	Enter offset measurement menu
REC	Enter points collection menu
RES	Enter resection program menu
REMS	Enter angle repeat measurement menu
MLM	Enter missing line measurement menu
S.O.	Enter stake out measurement menu
TILT	Display electronic level
REM	Enter remote elevation measurement menu
HARL	Horizontal angle display switching between HR and HL
ZA/%	Vertical angle display switching grade and zenith
OUT	Output the current measurement data via RS-232C port
AREA	Enter area measurement menu
ROAD	Enter road measurement menu
IHT	Enter instrument height setting menu
LSO.	Enter line stake out measurement menu
PROJ	Enter point projection measurement menu

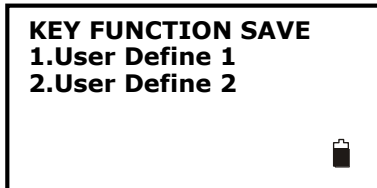

Key Save

1. Press key {1} to save the current key setting in User Define 1
2. Press key {2} to save the current key setting in User Define 2

Key Resume

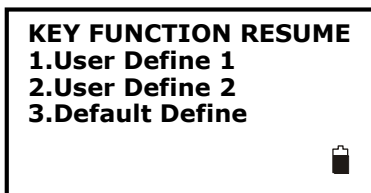

1. Press key {1} to resume the User Define 1 as the current Key setting
2. Press key {2} to resume the User Define 2 as the current Key setting
3. Press key {3} to resume the Default Define as the current

Key setting

3.9.7 EDM Setting

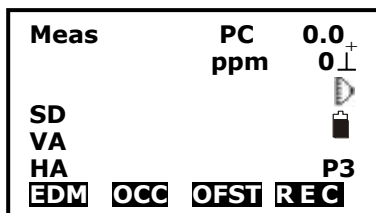

1. Press F1: [MEAS] in the status mode or select to enter into measure mode.

Press key {Func} to turn to page P3.

2. Press F1: [EDM] to enter into EDM setting.

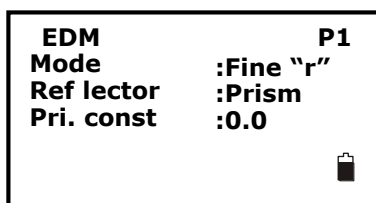

3. Change the settings if necessary. Press keys {▲}/ {▼} to select the first three items and press keys {◀} / {▶} to set the options.

4. Press Func key to turn to page 2.

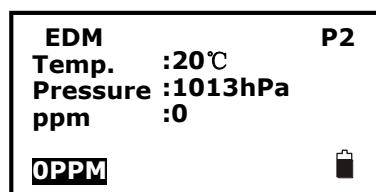

5. Press key {ESC} back to the previous mode.

Table 3-5 EDM setting

Item	Options
1.Mode	Fine "r" * / FineAVG 3 / Fine "s" / Rapid "s" / Tracking
2.Ref lector	Prism * / Sheet/ No prism
3.Pri. const	-99~99
4.Temp.	-30~60°C(20°C *)/-22~140°F
5.Pressure	500~1400hPa(1013hPa *); 375~1050mmHg(760mmHg *); 14.8~41.3 inchHg (29.9inchHg *) 500~1400mbar(1013mbar *); 7.2~20.3Psi(14.7Psi *)
6.ppm	-499~499(0 *), Press F1: [0PPM] to set temperature, pressure and ppm as factory setting.

NOTE:

- Options with the symbol " *" are the factory setting.
- Ppm value could be calculated by inputted temperature and pressure, or input directly. If the option of "ppm correct" is set as "Yes", the temperature, pressure and ppm can not be inputted by hand.
- This operation is also available in stake out mode.
- You can press star{★}/F1[EDM] key to enter EDM setting menu directly.

4. Angle Measurement

4.1 Measure a Horizontal Angle of Two Points

Meas	PC	0.0	
	ppm	0	
VD			
VA	85° 55' 50"		
HA	0° 00' 00"	P1	
DIST	SHV1	SHV2	0SET

1. Sight the 1st target.

Press F4: [0SET] twice to set the 1st target as 0° at P1 in the measure mode.

Press [SHV1] or [SHV2] to change display status firstly if in distance mode.

Meas	PC	0.0	
	ppm	0	
VD			
VA	85° 55' 50"		
HA	156° 13' 14"	P1	
DIST	SHV1	SHV2	0SET

2. Sight the 2nd target. The displayed value is the included angle between two points.

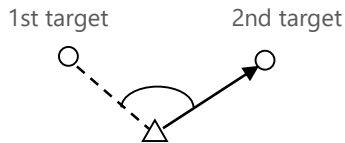

4.2 Set the Horizontal Angle to a Required Value

```

Meas          PC    0.0
                ppm  0
VD
VA 302.5432gon
HA 0.0000gon   P2
CORD  MENU  HOLD
  
```

```

Set H Angle
1. Azimuth
2. Back sight
  
```

```

Azimuth 399.9998
Tgt.H      0.000m
PT#
Observe point!
                OK
  
```

```

Meas          PC    0
                ppm  0
VD
VA 302.5432gon
HA 399.9998gon   P2
CORD  MENU  HOLD
  
```

1. Take your instrument sight the 1st target.
Press F4: [HSET] at P2 in the measure mode.

2. Select the first item 1. Azimuth, and input the required value in Azimuth filed, then press {ENT} to save the value. And it displays as the horizontal angle.

The range and format of the input value:

gon: 0~399.9999

degree: 0~359.5959

mil: 0~6399.990

3. Sight the 2nd target. The horizontal angle from the 2nd target to the value set as the horizontal angle is displayed.

NOTE: Pressing [HOLD] performs the same function as above. The horizontal angle is in hold status when [HOLD] is flashing, press [HOLD] again to release the hold status.

5. Distance Measurement

Please set the following items before distance measurement:

- Measurement condition (See §3.8.1 Measure Condition Setting)
- EDM (See §3.8.6 EDM setting)

【Procedure of distance measurement】

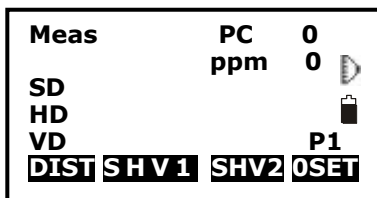

1. Aim at the target, press F3: **[SHV2]**, the display mode of basic measurement will change to SD/HD/VD mode, and then press F1:**[DIST]** to start measure distance.

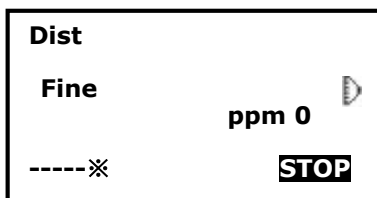

2. The symbol “*” moves continually when measuring distance. Distance measuring mode, prism const and ppm value are also presented.

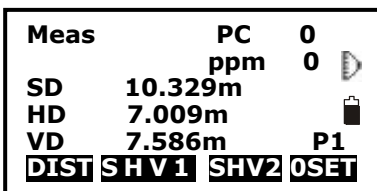

3. Press F4: **[STOP]** to finish measurement. The “SD”, “HD”, and “VD” will display as shown left.

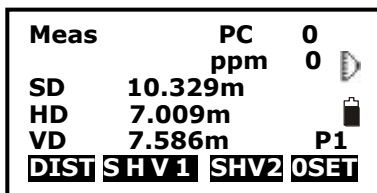

4. Press F3: **[SHV2]**, SD/HD/VD and SD/VA/HA are displayed alternatively.

NOTE:

- Make sure that the target setting in the instrument matches the type of target used.
- If the objective lens is dirty, it will affect the accurate of measured results. Dust it off with your special brush and wipe it with your special cloth (in your carrying case) before putting away.
- If an object with a high reflective factor (metal, white surface) exists between the instrument and the target when measuring, the accuracy of the measured results will be affected.
- An angle is also able to be measured when distance measurement.
- Measurement will automatically stop after a single measurement if the EDM mode is single (Fine "S" / Rapid "S").
- If the distance measurement mode is average "Fine AVG", the measured distances are displayed as "-1","-2","-3"..."-9" in turn, and the average value will display behind "-A" once the selected time's measurement has been finished.

6. Coordinate Measurement

It is possible to find the 3D coordinates of a target by coordinate measurement. Please input the occupied coordinate, instrument height, target height, backsight coordinate (or azimuth angle) and azimuth before coordinate measurement.

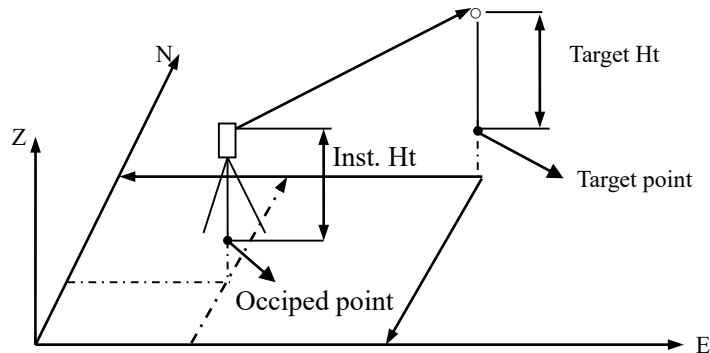

6.1 Input the Occupied Point Data

【Procedure of inputting occupied point data】

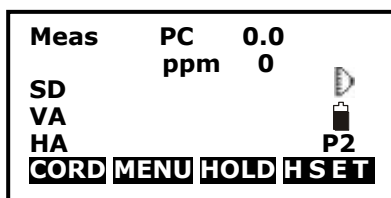

1. Measure the height of target and instrument with a tape, etc.

2. Press F1: [CORD] at P2 in the measurement mode.

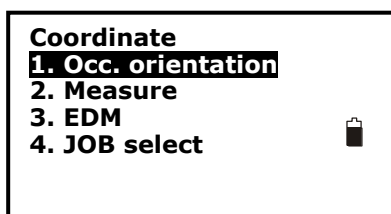

3. Select "1. Occ. orientation".

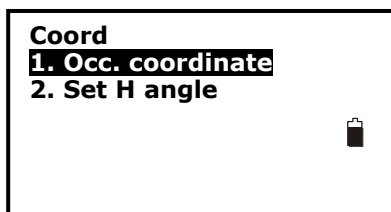

4. Select "1. Occ. coordinate" to input the occupied coordinates, instrument height and target height in corresponding field.

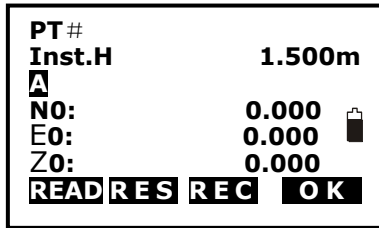

5. Press F3: **[REC]** to record the data in active occupied data list, see “§18.1 Record Occupied Data”. You could press F1: **[READ]** to read the existed data for occupied point from memory. You could also press F2: **[RES]** to enter Resection program to get the station point coordinate, see “§12. Resection”.

Press F4: **[OK]** to confirm your setting.

How to read the existed data:

Known point data, coordinate data and instrument occupied data in the current JOB and coordinate search JOB can be read. Confirm that the JOB containing the coordinates you want to read is already selected in coordinate search JOB, see “§22.2 Select a JOB”.

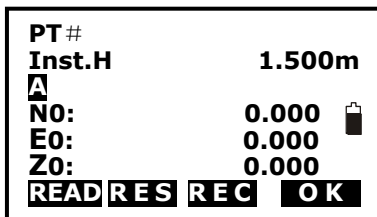

1. Press F1: **[READ]** when inputting the coordinate.

2. The list of existed coordinate displays as shown left:

Occ.: Occupied data saved in the current JOB or in the coordinate search JOB.

Coord: Measured coordinate data saved in the current JOB or in the coordinate search JOB

Pt#: Known point data saved in the current JOB or in the coordinate search JOB.

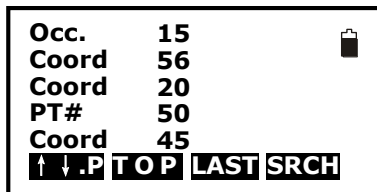

- [**↑↓.P**]: Press keys {**▲**}/**{▼}** to move one by one.
- [**↑↓.P**]: Press keys {**▲**}/**{▼}** to turn the previous/next page.
Press F1 to switch between [**↑↓.P**] status and [**↑↓.P**] status.
- [**TOP**]: Press it and the first point on the first page will display.
- [**LAST**]: Press it and the last point on the last page will display.
- [**SRCH**]: Press it to enter into “coordinate data search” mode. Input the required point number to search.

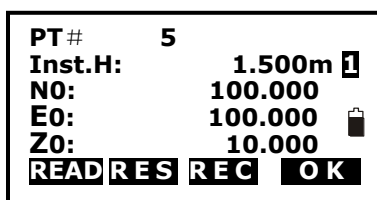

3. Select the required data and press the key **{ENT}**. The corresponding data will display. You could re-edit the data and it won't affect the original coordinate data.

4. Press F4: **[OK]** to save the setting.

NOTE:

- The point number that was read is displayed until the current JOB is changed or a new point number is selected.
- If more than two points with the same point name exist in the current JOB, the instrument finds the first recorded data only.

6.2 Azimuth Setting

The azimuth of backsight could be inverse calculated by the coordinates of occupied and backsight.

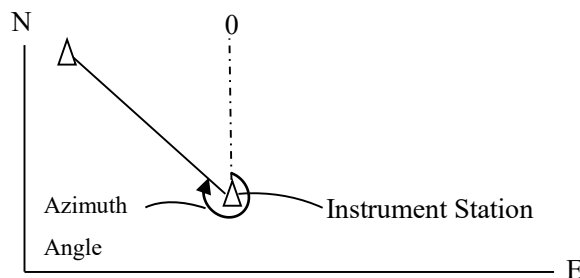

Set H angle	
1.Azimuth	
2.Back sight	

1. Select "**2. Set H angle**", see "§6.1 Input the occupied point data". Then select "**2. Backsight**".

Pt#	P20
Tgt.H	0.000m []
NBS:	20.000
EBS:	20.000
ZBS:	20.000
READ	OK

2. Input the coordinate of backsight. You could also press F1: **[READ]** to select existed point data. If you input the same coordinates with the occupied point, a message "Same coordinates" will appear and disappear in 5sec, please re-input the data.

Azimuth	450000
Tgt.H	0.000m
Pt#	
MEAS	REC OK

3. Press F4: **[OK]** to accept the inputted occupied and backsight coordinates, the calculated azimuth angle will display.

4. Aim at the backsight point, and then press F1: **[MEAS]** to check the backsight, or press F3: **[REC]** to record and set the station, then back to the previous mode. You could also press F4: **[OK]** to set the station, but the data will not be recorded.

NOTE:

You can select "1. Azimuth" to input the azimuth angle directly.

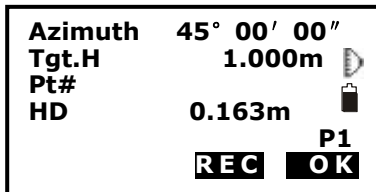

After input the coordinate of backsight, you can press F1: [MEAS] to check for backsight checking, HD between station and backsight, dHD and dVD between calculated backsight and measured backsight will be display.

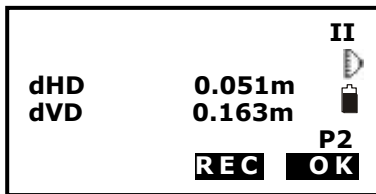

Press F3: [REC] to record and set the station, then back to the previous mode. You could also press F4: [OK] to set the station, but the data will not be recorded.

6.3 3D Coordinate Measurement

The target coordinate could be measured after the setting of occupied point and backsight azimuth.

The formula used to calculate:

$$N1 = N0 + S \times \sin Z \times \cos Az$$

$$E1 = E0 + S \times \sin Z \times \sin Az$$

$$Z1 = Z0 + S \times \cos Z + IH - TH$$

Where:

N0-E0-Z0: occupied point coordinates

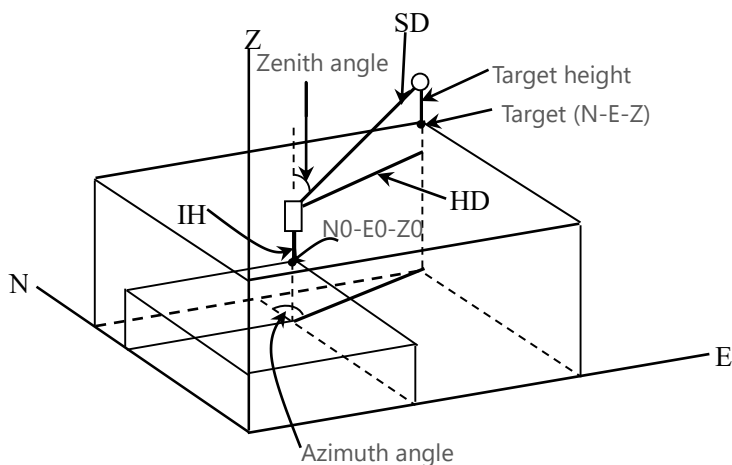

S: SD Z: Zenith angle Az: Azimuth angle

IH: Instrument height TH: Target height



【Procedure of 3D coordinates measurement】

Coordinate 1. Occ. Orientation 2. Measure 3. EDM 4. JOB select	
---	---

N 1000.000 E 1000.000 Z 10.466 VA 132.3648gon HA 150.3536gon MEAS TAGT REC	 
--	--

1. Aim at the target point.
2. Select "2. Measure" to start. The coordinate value of the target is displayed.
3. Press F2: **[TAGT]** to re-input the occupied data if necessary, see "\$6.1 Input the occupied point data". You can press F4: **[REC]** to record the data.
4. Aim at the next target, press F2: **[TAGT]** to re-input the target height if necessary, and press F1: **[MEAS]** to continue. Follow this operation till all targets have been measured.
5. Press key {ESC} back to the coordinate mode.

7. Stake out Measurement

Stake out measurement is used to stake out the required point. The difference between the previously inputted data to the instrument (the stake out data) and the measured value can be displayed by measuring the horizontal angle, distance or coordinates of the sighted point.

The horizontal angle difference and distance difference are calculated and displayed using the following formulas:

Horizontal angle difference

dHA= Horizontal angle of stake out data - measured horizontal angle

Distance difference

Distance Displayed item

SD: S-O SD= measured slope distance - slope distance of stake out data

HD: S-O HD= measured horizontal distance -horizontal distance of stake out data

VD: S-O VD= measured height difference - height difference of stake out data

NOTE:

- ◆ Stake out data can be input in various modes: SD, HD, VD, coordinates and REM measurement.
- ◆ EDM settings could be set in this mode.

7. 1 Distance Stake out

The point to be found based on the horizontal angle from the reference direction and the distance from the instrument station.

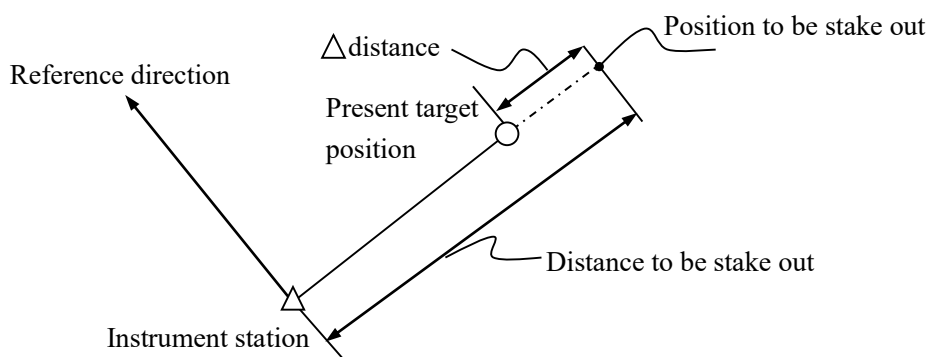

【Procedure of distance stake out measurement】

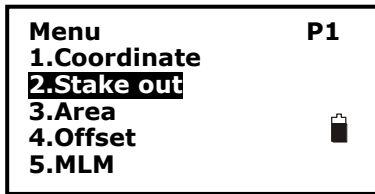

1. Press F2: **[MENU]** at P2 in the measure mode.
Select **"2. Stake out"**.

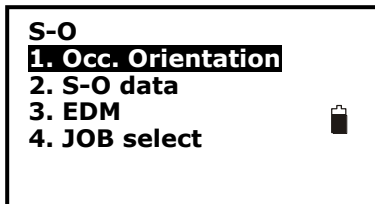

2. Select **"1. Occ. Orientation"**.
Select **"1. Occ. Orientation"**, Input the occupied orientation data, see **"§6.1 Input the occupied point data"**.
Then set the azimuth angle of the backsight point, see **"§6.2 Azimuth setting"**.

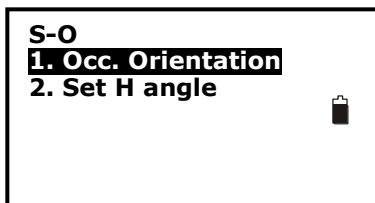

3. Select **"2. S-O data"**.

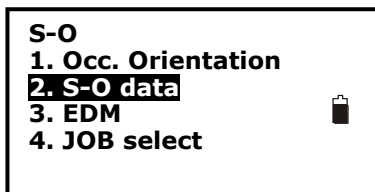

4. Select **"2. Angle & Dist"**.



Press F2: **[SHV]** to shift between S-O SD, S-O HD, S-O VD.
Input the following items:

SD/HD/VD: distance from the instrument station to the position to be stake out;

Ang.: included angle between the direction of the reference and the point to be stake out. See **"§ 4.2 Set the Horizontal Angle to a Required value"**.

Press F4: **[OK]** to set the input values.

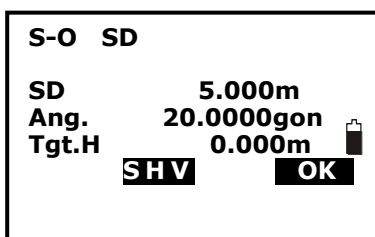

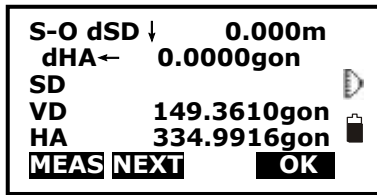

6. Horizontally rotate the instrument until "dHA" is near 0 and set the target on the sight line.

Press F1: [MEAS] to start distance measurement.



7. The difference of measured and stake out value "S-O dSD" is displayed. Move the prism forward and backward until "S-O dSD" is 0m.

←: Move the prism left

→: Move the prism right

↓: Move the prism forward

↑: Move the prism backward

Press F4: [OK] back to stake out mode.

7.2 Coordinates Stake out Measurement

After setting coordinates for the point to be stake out, the instrument calculates the stake out HA and HD. By selecting the HA and then the HD stake out functions, the required coordinate location can be stake out.

To get the Z coordinate, attach the target to a pole etc., with the same target height.

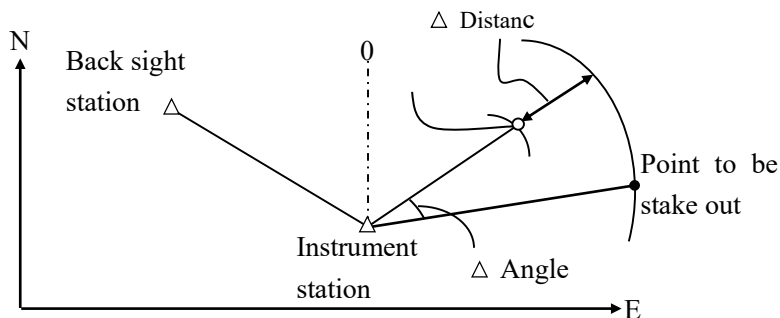

【Procedure of coordinate stake out measurement】

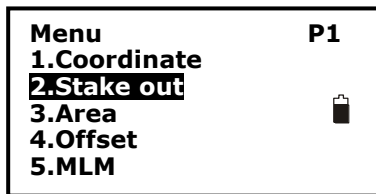

1. Press F2: [MENU] at P2 in the measure mode.
Select "2. Stake out".

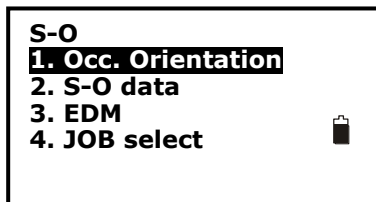

2. Select "1. Occ. Orientation".
Input the occupied orientation data, see "\$6.1 Input the occupied point data".
Then set the azimuth angle of the backsight point, see "\$6.2 Azimuth setting".



3. Press Esc, then Select "2. S-O data", then select "3. Coord".

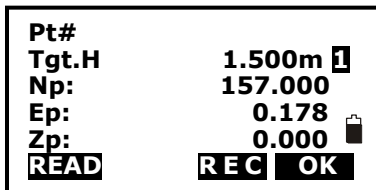

4. Input the coordinates of the stake out point.
Press F1: [READ] to read the existed coordinates as stake out coordinate.
Press F4: [OK] to set the data.

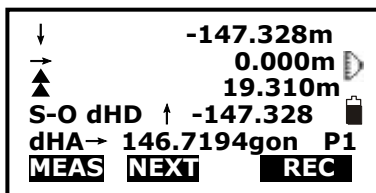

5. Press F1: [MEAS] begin coordinate stake out measurement. Move the prism to find the point to be stake out.
: Move the prism upward
: Move the prism downward

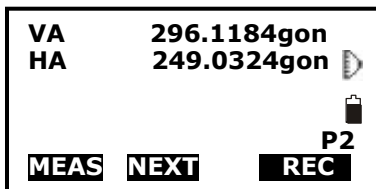

Press key {ESC} back to stake out mode.

7.3 REM Stake out Measurement

Perform this operation to find a point where a target cannot be directly installed, see “§11 REM”.

【Procedure of REM stake out measurement】

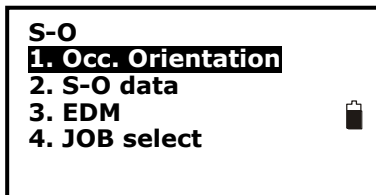

1. Set a target directly below or directly above the point to be found, then use a measuring tape etc. to measure the target height (height from the surveying point to the target). Press F2: [MENU] at P2 in the measure mode, then select “2. Stake out”.



2. Select “2. S-O data”, then select “1. Height”.

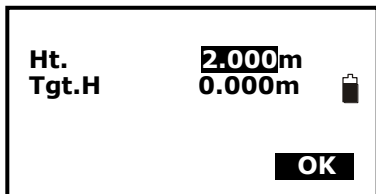

3. Input height from the surveying point to the position to be stake out. Then press F4: [OK] to set the data.

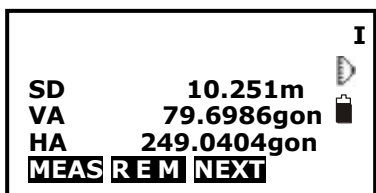

4. Press F2: [REM] to begin REM stake out measurement.

Move telescope to find the point to be stake out.

: Move the telescope near the zenith

: Move the telescope near the nadir

Press key {ESC} back to stake out mode.

8. Area

Calculate an area shaped with several points. The coordinate data of the points could be either measured or input by hand.

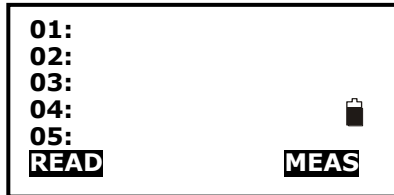

Input:

Coordinates: P1 (N1, E1)

P2 (N2, E2)

P3 (N3, E3)

...

Output:

Area: S

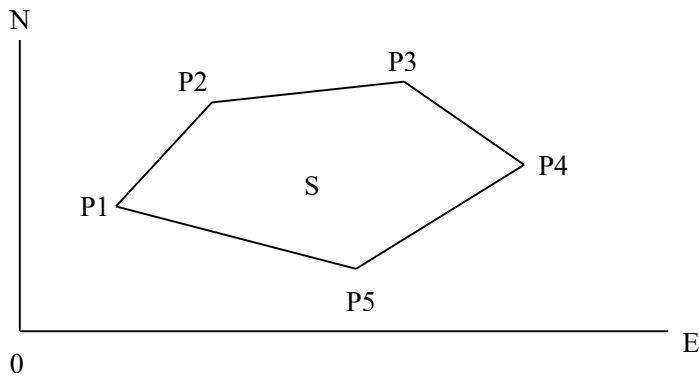

NOTE:

- The number of points: 3 ~ 30.
- Make sure these points must be measured or listed clockwise or anticlockwise, or mistake will result.

8.1 Area Calculation by Measured Data

【Procedure of area calculation】

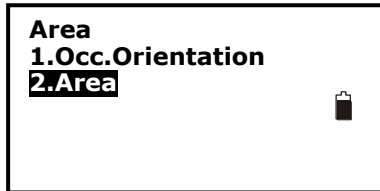

1. Select F2: **[MENU]**/ 3. Area /2. Area.

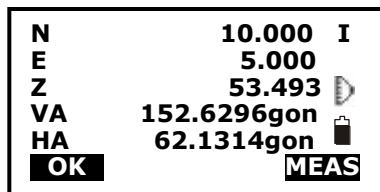

2. Aim at the first point, and then press F4: **[MEAS]**.

3. Press F4: **[MEAS]** to re-measure distance or press F1: **[OK]**, the measured data is set as "Pt-01".

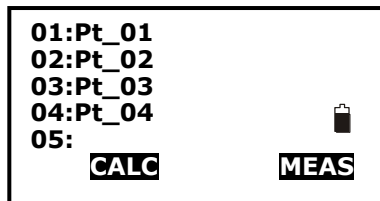

4. Repeat steps 2 and 3 till all points are measured one by one. Make sure measure them clockwise or anticlockwise. Press F2: **[CALC]** and the calculated area will display.

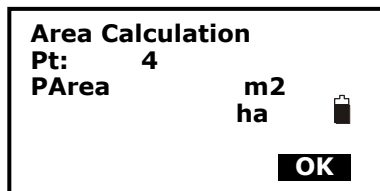

5. Press F4: **[OK]** back to menu mode.

8.2 Area Calculation by Reading Existed Coordinates

【Procedure of area calculation】

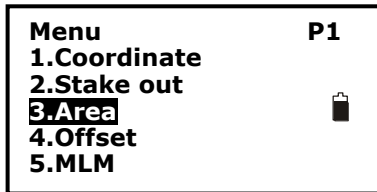

1. Select F2: [MENU]/ 3. Area /2.Area.

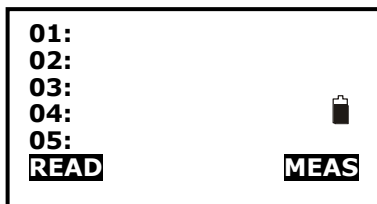

2. Press F1: [READ] to display existed coordinates data list.



3. Pt#: Known point data saved in the active JOB or in the coordinate search JOB.

Occ./Coord: Coordinate data saved in the active JOB or in the coordinate search JOB.

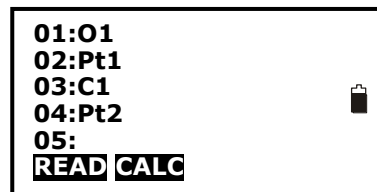

4. Select the first point in the list and press key {ENT} to set.

The selected point is set as "Pt-01".

5. Repeat steps 2 and 4 till all points are selected.

Make sure read the points clockwise or anticlockwise.

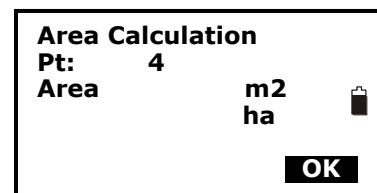

6. Press F2: [CALC], and the calculated area will display. Press F4: [OK] to escape.

9. Offset Measurement

Offset measurement are performed in order to find a point where a target cannot be installed directly or to find the distance and angle to a point which cannot be sighted.

It is possible to find the distance and angle to a point you wish to measure (target point) by installing the target at a location (offset point) a little distance from the target point and measuring the distance and angle from the surveying point to the offset point.

The target point could be found in the following three ways.

9.1 Single-distance Offset Measurement

Finding a point by entering the horizontal distance from the target point to the offset point.

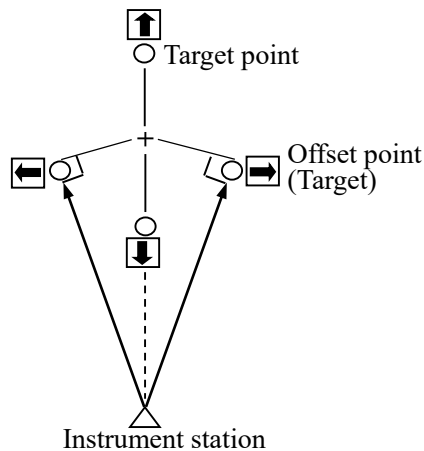

When the offset point is positioned to the left or right of the target point, make sure the angle formed by lines connecting the offset point to the target point and to the instrument station is almost 90°.

When the offset point is positioned in front of or behind the target point, install the offset point on a line linking the instrument station with the target point.

【Procedure of single-distance offset measurement】

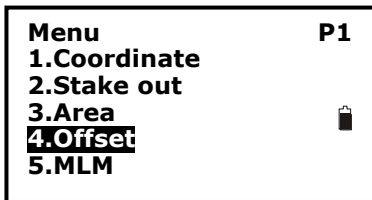

1. Set the offset point close to the target point and measure the distance between them, then set up a prism on the offset point.

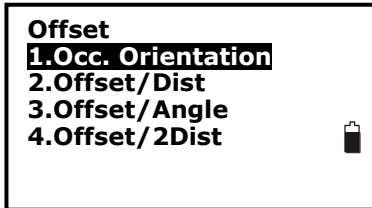

2. Aim at the offset point and press F1: [MEAS] to measure the distance at P1 in measure mode.

3. Select [MENU]/4. Offset, or press F3: [OFST] at P3 of basic measurement menu.

4. Select "1. Occ. orientation" to input the instrument occupied data, see "§6.1 Input the occupied point data".

5. Select "2. Offset/Dist".

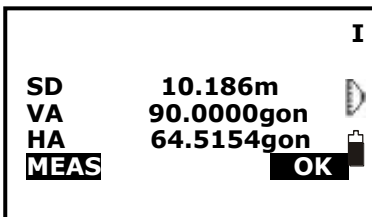

6. User could press F1: [MEAS] to re-measure the offset point or press F4: [OK] to the next step.

7. Input distance and direction of offset point:

① Dist: horizontal distance from the target point to the offset point.

② Direc: direction of the offset point.

←: on the left of the target point

→: on the right of the target point

↓: in front of the target point

↑: at back of the target point

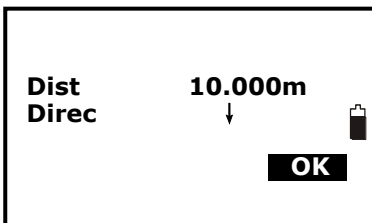

8. Press F4: [OK] to calculate and display the distance and angle of the target point.

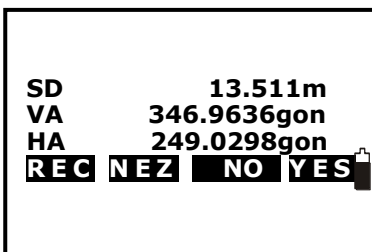

9. Press F1: [REC] to save;

Press F2: [NEZ] to display NEZ coordinate;

Press F3: [NO] back to step 6;

Press F4: [YES] back to offset mode.

9.2 Angle Offset Measurement

Sighting the direction of the target point to find it from the included angle. Set offset points for the target point on the right or left sides of and as close as possible to the target point and measure the distance to the offset points and the horizontal angle of the target point.

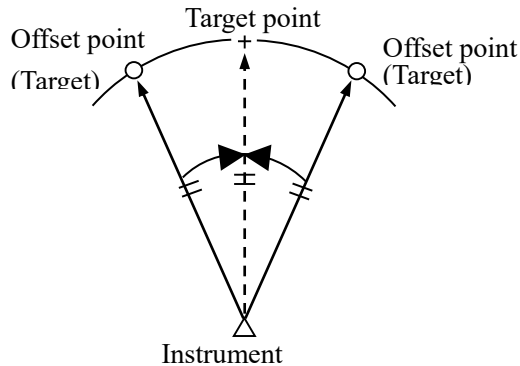

【 Procedure of angle offset measurement 】

Menu	P1
1.Coordinate	
2.Stake out	
3.Area	
4.Offset	
5.MLM	

1. Set the offset points close to the target point (making sure the distance from the instrument station to the target point and distance to the offset point are same, the height of the offset points and the target point are the same), then use the offset points as the target.

Offset	
1.Occ. Orientation	
2.Offset/Dist	
3.Offset/Angle	
4.Offset/2Dist	

2. Aim at the offset point and press F1: **[MEAS]** to measure the distance at P1 in measure mode.

3. Select **[MENU]** at P2 in measure mode, and then select "4. Offset", or press F3: **[OFST]** at P3 directly.

4. Select "3. Offset/Angle" after inputting instrument occupied data, see "\$6.1 Input the occupied point data".

SD	10.186m	I
VA	90.000gon	
HA	64.5154gon	
Aim at target?		
MEAS		OK

5. Accurately sight the direction of the target point and press F4: **[OK]**, the distance and angle of the target point are displayed.

SD	13.511m	I
VA	346.9636gon	
HA	249.0298gon	
Aim at target?		
REC	NEZ	NO YES

6. After finishing measurement:

Press F1: **[REC]** to save;

Press F2: **[NEZ]** to display NEZ coordinate;

Press F3: **[NO]** back to step 6;

Press F4: **[YES]** back to offset mode.

9.3 Dual-Distance Offset Measurement

By measuring the distance between the target point and the two offset points. Set two offset points (1st target and 2nd target) on a straight line from the target point, measure the 1st and 2nd target, then input the distance between the 2nd target and the target point to find the target point.

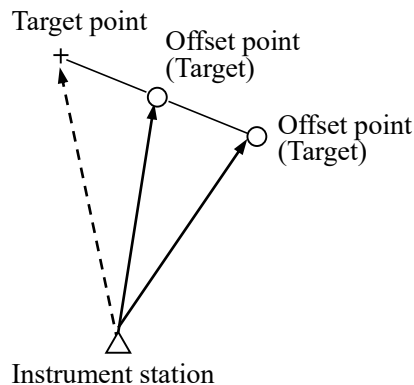

【Procedure of dual-distance offset measurement】

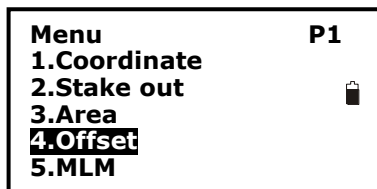

1. Set two offset points (1st target, 2nd target) on a straight line from the target point and use the offset points as target.
2. Select [**MENU**] at P2 in measure mode, and then select "**4. Offset**", or press F3: [**OFST**] at P3 directly.



3. Select "**4. Offset/2Dist**" after inputting the instrument occupied data, see "§6.1 Input the occupied point data".

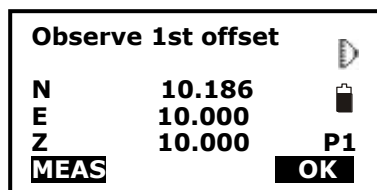

4. Aim at the 1st target and press F1: [**MEAS**] and measured data will display. Press F4: [**OK**] to accept this value.

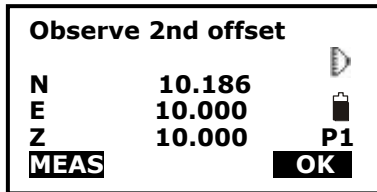

5. Sight the 2nd target, press F1: **[MEAS]** and measured data will display, press F4: **[OK]** to accept this value.



6. Input the distance from 2nd point to the target point and press key {ENT}, the angle and distance of the target point are displayed.

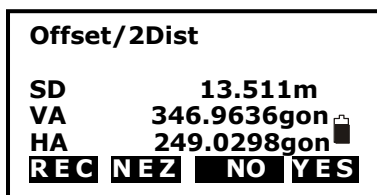

7. Press F1: **[REC]** to save;

Press F2: **[NEZ]** to display NEZ coordinate;

Press F3: **[NO]** back to step 6;

Press F4: **[YES]** back to offset mode.

10. MLM

MLM is used to directly measure slope distance, horizontal distance and the height difference from one base point to other points without moving the instrument.

NOTE:

- The last measured data could be set as the base point for the next starting operation.
- The height difference between one point and the base point could be displayed as grade mode.

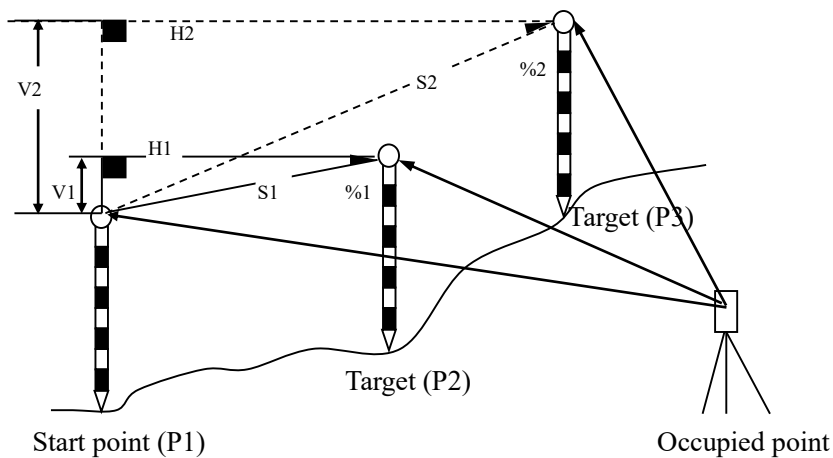

10.1 Measuring Distance between Two or More Points

【Procedure of measuring】

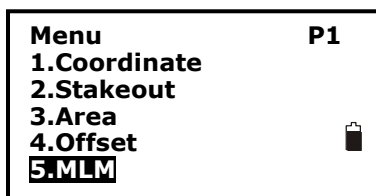

1. Press F2: [MENU] at P2 in the measure mode.
Select "5. MLM".

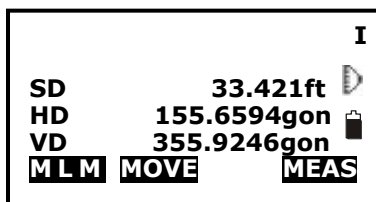

2. Aim at the start point P1, then press F4: [MEAS] and the measured data will display.
3. Aim at the target point P2 and press F1: [MLM] to begin measure, SD, HD, VD will display.

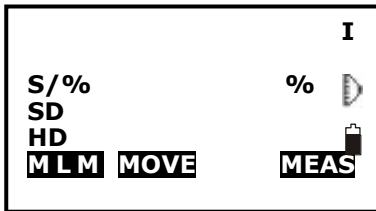

4. Aim at the next point P3 and press F1: [MLM] to begin measure. Repeat this operation to measure other target points.
5. Press F2: [MOVE], the last target measured becomes the new starting position to perform MLM of next target. Press F4: [MEAS] to re-measure the starting position.
6. Press key {ESC} back to menu mode.

NOTE:

Once "S/%" is displayed, the distance between two points is displayed as the gradient

10.2 Change the Starting Point

The previous measured data could be set as the base point for the next operation.

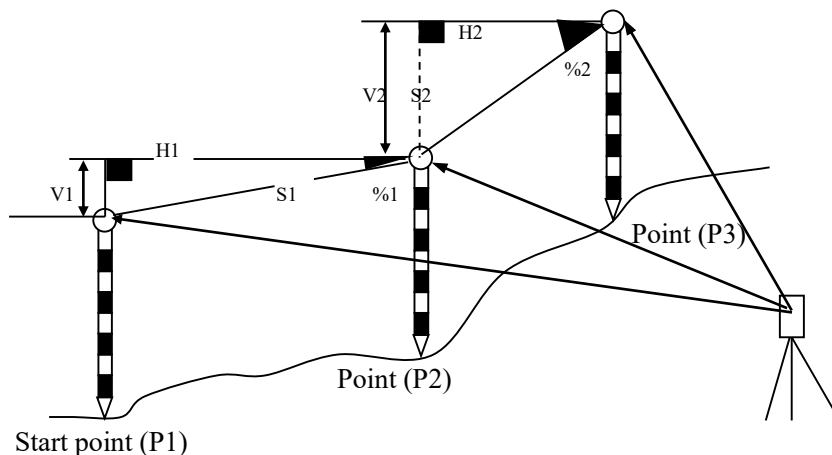

【Procedure of changing the starting point】

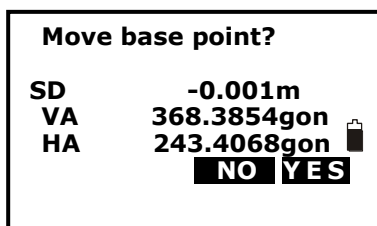

1. Measure the start point P1 and the first target P2 following above steps 1, 2 and 3.
2. After measuring the two points, press F2: [MOVE], and press F4: [YES] to set the last measured point as new starting point, or press F3: [NO] to give up.

11. REM

REM is a function used to measure the coordinate and height to a point where a target cannot be directly installed such as power lines, overhead cables or bridges, etc.

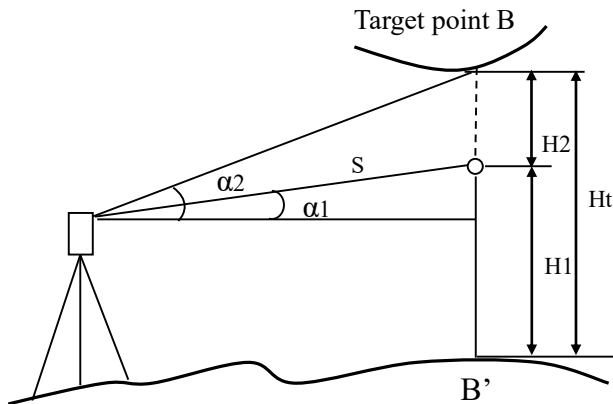

Here is the equation used to calculate the data presented in above figure:

$$H_t = H_1 + S \cos \alpha_1 \tan \alpha_2 - S \sin \alpha_1$$

【Procedure of REM】



1. Set a target directly under or directly over the object and measure the target height with a tape measure etc.
2. Press F2: [MENU] on P2 of the basic measurement mode, then press Func key to turn to page 2, then select "1.REM" on P2 to enter into REM status.

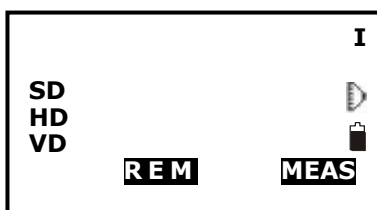

3. Reference point measurement.
 Aim at the prism accurately, and press F4: [MEAS] to measure distance. Press F4: [STOP] and the measured data are displayed. Press F4: [MEAS] to re-measure.

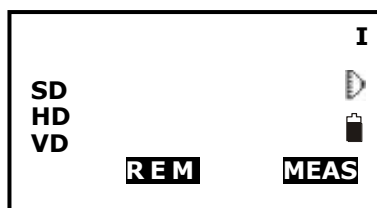

4. Aim at the target accurately and press F2: [REM]. The height from ground to the target is displayed in "Ht". Press F4: [MEAS] to repeat and press key {ESC} back to menu mode.

12. Resection

Resection program is used to determine the coordinates of an instrument station (unknown) by measuring several known points. Coordinate data in memory could be read.

Input

Coordinates of known points: X_i, Y_i, Z_i

Measured HA: H_i

Measured VA: V_i

Measured distance: D_i

Output

Coordinate of occupied data: X_o, Y_o, Z_o

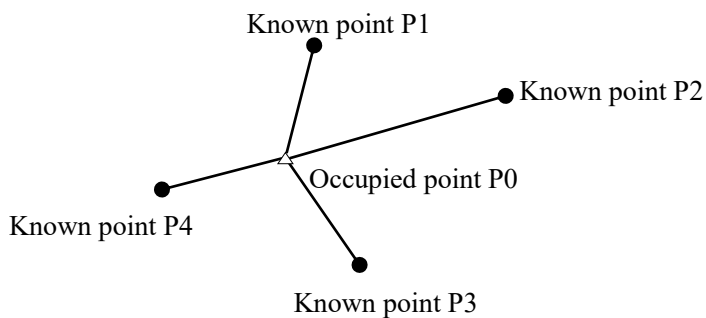

NOTE:

- All N, E, Z value or only Z value of the occupied point is calculated by measuring known points.
- Coordinate resection measurement overwrite the N, E, Z data of the instrument occupied point, while elevation resection measurement overwrite Z data only. Perform resection measurement, see “§ 12.1 Coordinate Resection” and “§ 12.2 Elevation Resection”.
- Inputted known coordinate data and calculated data could be recorded in the current JOB.

12.1 Coordinate Resection

Between 2 and 5 known points can be measured by distance measurement and angle measurement.

【Procedure of coordinate resection】

Menu	P2
1.REM	
2. Resection	
3. Point Projection	
4. Line stake out	
5. Traverse	

1. Select [**MENU**] at P2 of basic measurement mode, then press Func key to turn to page 2, and then select "**2. Resection**", or select [**RES**] at P3 directly.

Resection	
1.NEZ	
2.Elevation	

2. Select "**1.NEZ**" and input known point data. After inputting the data of the first known point, press F3: [**NEXT**] to input the second point data.

Pt#	
Tgt.H	m 1
Np:	
Ep:	
Zp:	
READ REC NEXT MEAS	

3. After all known points data have been set, press F4: [**MEAS**].
Press F1: [**READ**] to read existed coordinate data.

Resection	No.1PT
N	
E	
Z	
Pt#	
DIST ANG	

4. Sight the first known point and press F1: [**DIST**] to begin measurement. If known points number is more than two, F2: [**ANG**] will display, you can confirm the known point by angle measurement.

Resection	No.1Pt	I
SD	10.188m	
VA	189.9284gon	
HA	47.2432gon	
Tgt.H	 m	
	NO YES	

5. Press F4: [**YES**] to use the measured data of the first known point.
Press F3: [**NO**] to re-measure this point.
You can also input target height here.

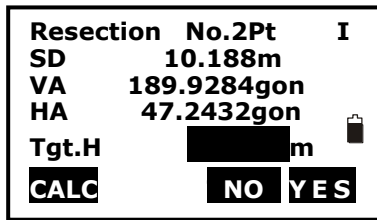

6. Repeat procedures 4 and 5 of other points.

When the minimum quantity of measured data required for the calculation is present, [CALC] will be displayed.

Press F1: [CALC] to calculate. Instrument occupied coordinate and standard deviation are displayed.

Press F3: [NO] to re-measure the point.



7. Press F1: [NEXT] to add other known points.

Press F2:[DISP] to view the tolerance of measured known points

Press F3: [REC] to record the calculated result.

Press F4: [OK] to finish coordinate resection.

The instrument occupied coordinate setting is finished.

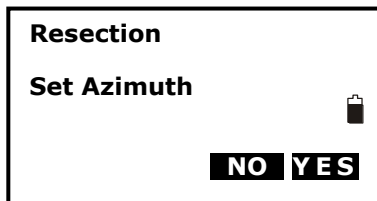

8. In this <Set Azimuth> screen, aim the first point then press F4: [YES] to set the first known point as backsight point and azimuth, press F3: [NO] to back to measure mode.

12.2 Elevation Resection

Only Z (elevation) of an instrument station is determined by this measurement. Between 1 and 5 known points can be measured by distance measurement only.

【 Procedure of elevation resection 】



1. Press F2: [MENU] on P2 of the basic measurement mode, then press Func key to turn to page 2, and then select "7. Resection", or press F4: [RES] at P3 directly.

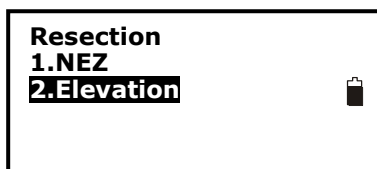

2. Select "2. Elevation" and input the known point.

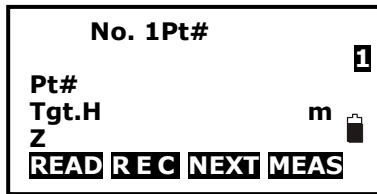

3. After setting the elevation for the first known point, press F3: **[NEXT]** to set the second point data.

4. After all known points data have been set, press F4: **[MEAS]**.

Press F1: **[READ]** to read existed coordinate data.

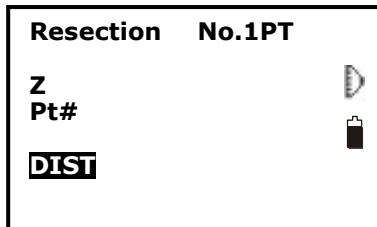

5. Sight the first known point and press F1: **[DIST]** to begin measurement. The measured data are displayed.

6. Press F4: **[YES]** to use the measured data of the first known point data.

Press F3: **[NO]** to re-measure the point. You can also input target height here.

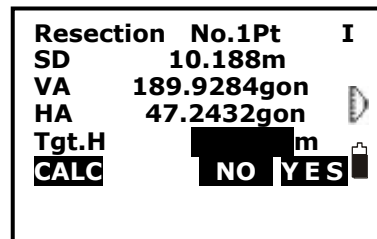

After finishing two measurements, **[CALC]** will be displayed.

6. Press F1: **[CALC]** to calculate. Instrument occupied elevation and standard deviation are displayed.

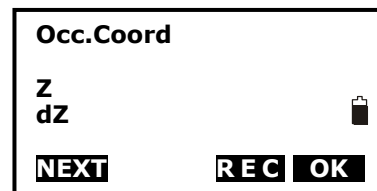

7. Press F1: **[NEXT]** to add other known points.

Press F3: **[REC]** to record the calculated result.

Press F4: **[OK]** to finish elevation resection.

Only Z (elevation) of the instrument occupied coordinate is set.

N and E values would not be overwritten.

12.3 Resection Calculation Process

The N, E coordinates are found by angle and distance measurement equations, and the instrument occupied coordinates are found using the least squares method. The Z coordinate is found by treating the average value as the instrument occupied coordinate.

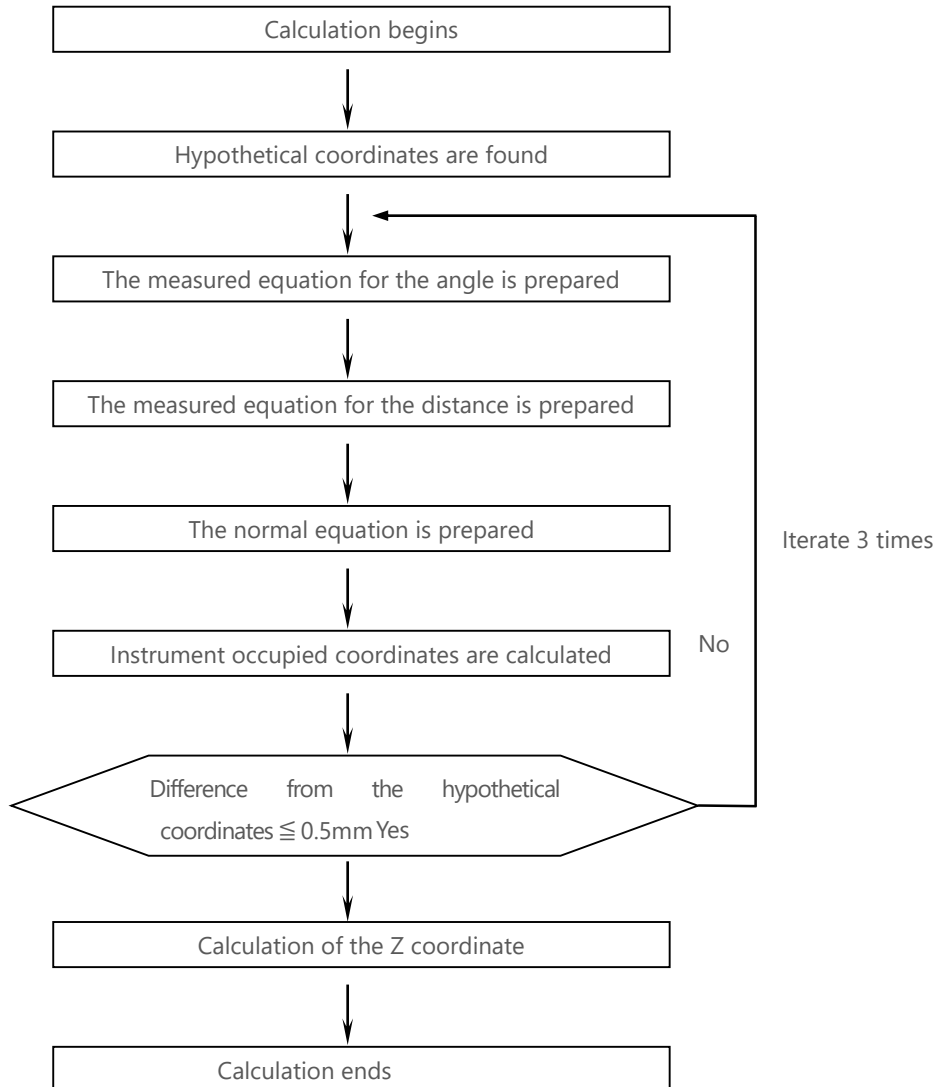

12.4 Precautions When Performing Resection

In some cases it is impossible to calculate the coordinates of occupied point if the unknown point and three or more known points are arranged on the edge of a single circle. It is also impossible to calculate if the included angle between the known points is too small. It is difficult to imagine that the longer the distance between the instrument occupied and known points, the narrower the included angle between the known points. Be careful for the points can easily be aligned on the edge of a single circle.

An arrangement such as shown below is desirable.

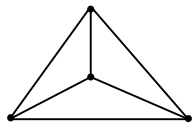

△▲: unknown point

○●: known point

It is sometimes impossible to perform a correct calculation such as shown below.

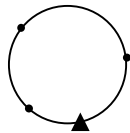

When they are on the edge of a single circle, take one of the following methods:

- (1) Move the instruction station as close as possible to the center of the triangle.

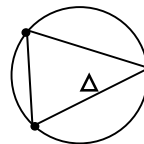

- (2) Measure one more known point which is not on the circle.

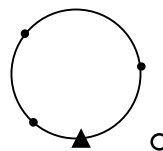

- (3) Perform a distance measurement on at least one of the three points.

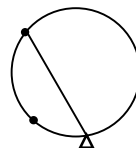

13. Point Projection

Point projection is used for projecting a point to an established baseline. The point to project can be either measured or input. Displays the distances from the first point and point to project to the position at which a line extending from point to project intersects the baseline at right angles.

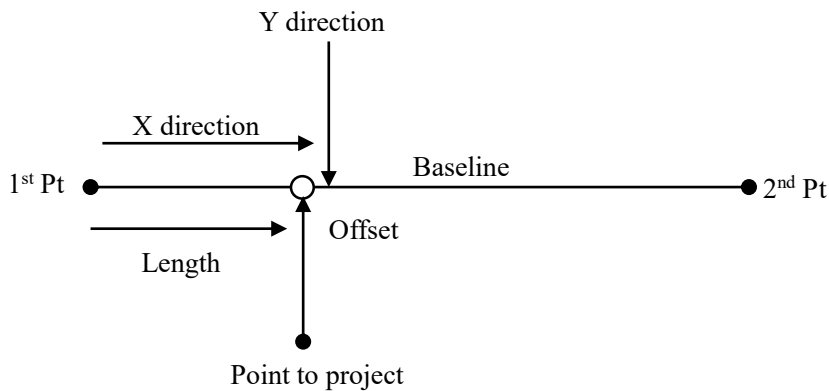

Length: Distance along the baseline from 1st point to 2nd point (X direction).

Offset: Distance from point to project to the position at which a line extending from point of project intersects the baseline at right angles (Y direction).

13.1 Define Baseline

【Procedure of defining baseline】

Menu	P2
1.REM	▲
2.Resection	
3.Point projection	☑
4.Line stake out	
5.Traverse	

1. Press F2: [MENU] at P2 of basic measurement mode.

2. Turn to P2, select "3. Point projection".

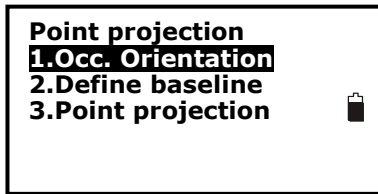

3. Input the instrument occupied data, see “§6.1 Input the occupied point data”.

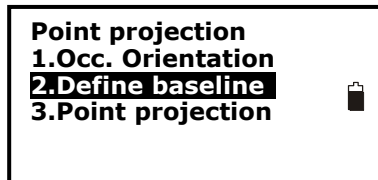

4. Select “2. Define baseline”.

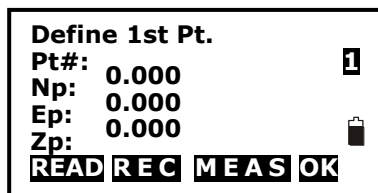

5. Input the first point data, or press F1: [READ] to use existed coordinates data, or press F3:[MEAS] to measure the point.

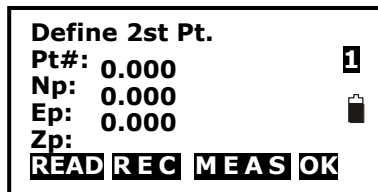

6. Press F4: [OK] to input the second point data.

7. Press F4: [OK] to finish defining baseline. The grade of the baseline will display.

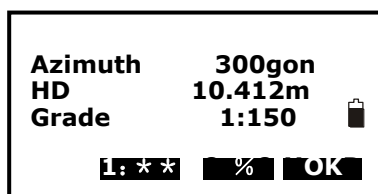

8. Press F2: [1:**] or F3: [%] to change the grade display mode.

NOTE:

Defined baseline could be used in both stake out line measurement and point projection.

13.2 Point Projection

The baseline must be defined before performing point projection.

【Procedure of point projection】

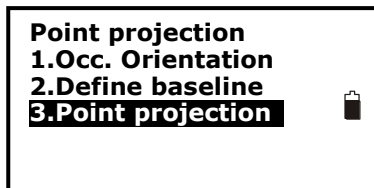

1. Select “3. Point projection” after finishing defining baseline.

2. Input the point coordinate.

Press F2: [MEAS] to measure the point to project.

When recording the data as a known point, press key {Func}, and press F2: [REC] on P2. Record method, see “§ 23.1 Input Known Point Coordinate by Keys”.

3. Press F4: [OK] to calculate Length, Offset and dVD will display.



Length: Distance along the baseline from 1st point to 2nd point (X direction).

Offset: Distance from point to project to the position at which a line extending from point of project intersects the baseline at right angles (Y direction)

dVD: Elevation between the baseline and the projected point.

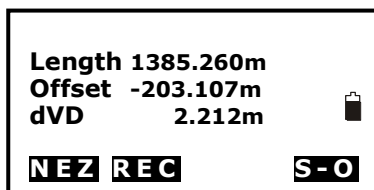

Press F1: [NEZ] to display switching between coordinate and distance data.

Press F2: [REC] to record the coordinate as a known data.

Press F4: [S-O] to switch to stake out measurement of the projected point. See “6 Stake out measurement”.

Press key {ESC} to continue point projection of a new point.

14. Stake out Line

Stake out line is used for stake out a required point at a designed distance from the base line and for finding the distance from the baseline to a measured point.

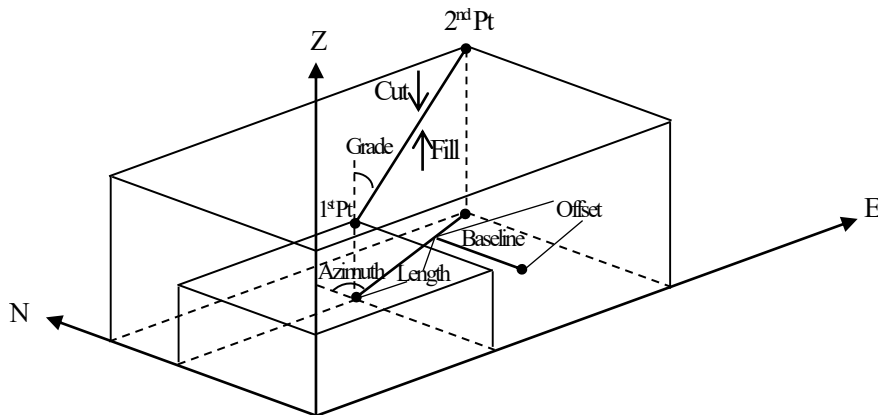

14.1 Define Baseline

【Procedure of defining baseline】

To perform stake out line, please define a baseline first. The baseline can be defined by inputting coordinates of the two points.

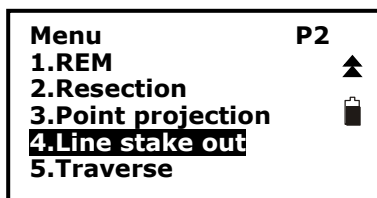

1. Press F2: **[MENU]** on P2 of the basic measurement mode.

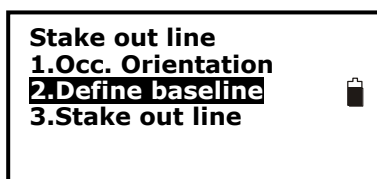

2. Turn to P2, select "**4. Stake out line**".

3. Input the instrument occupied data, see "§6.1 Input the occupied point data".

4. Select "**2. Define baseline**", following operations see "§13.1 Define baseline" procedures 5, 6 and 7.

14. 2 Stake Out Line-Point

This measurement can be used to find the required point coordinates by inputting the length and offset based on baseline.

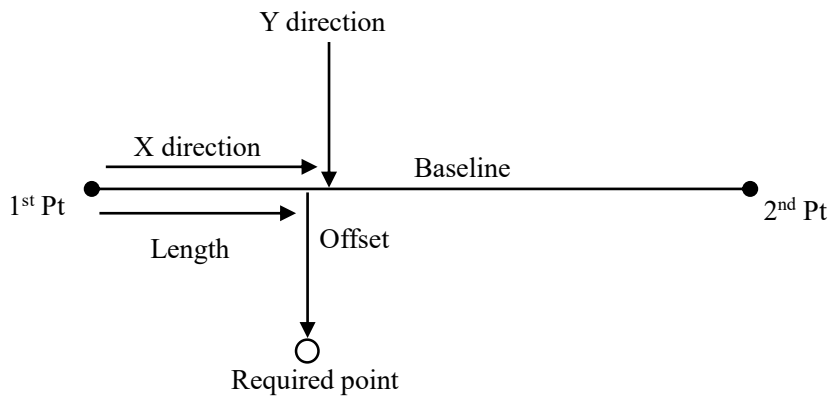

Length: Distance along the baseline from 1st point to the position at which a line extending from the required point intersects the baseline at right angles (X direction)

Offset: Distance from the required point to the position at which a line extending from the required point intersects the baseline at right angles (Y direction).

【Procedure of stake out】

Stake out line
1. Occ. Orientation
2. Define baseline
3. Stake out line

1. Select "3. Stake out line" after defining a baseline.

Stake out line
1. Point
2. Line

2. Select "1. Point"

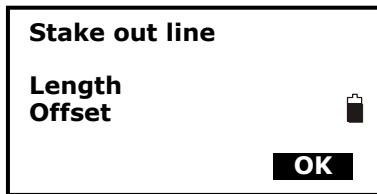

3. Input values of length and offset, then press F4: **[OK]**, the coordinate of the required point is calculated and displayed.

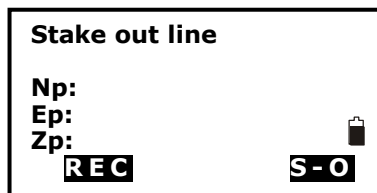

4. Press F2: **[REC]** to record the value as a known point, see “§20.1 Input Known Point Coordinate by Keys”.

Press F4: **[S-O]** to stake out the required point, see “§7. Stake out Measurement”.

Press key {ESC} to continue.

14.3 Stake out Line/Line

Stake out line-line tells how far horizontally the measured point is from the baseline and how far vertically the measured point is from the connected line. Make sure to define a baseline before this operation.

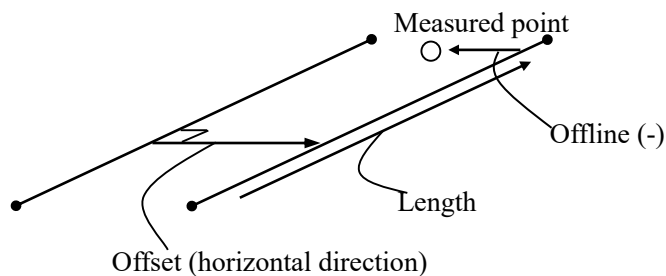

Profile view

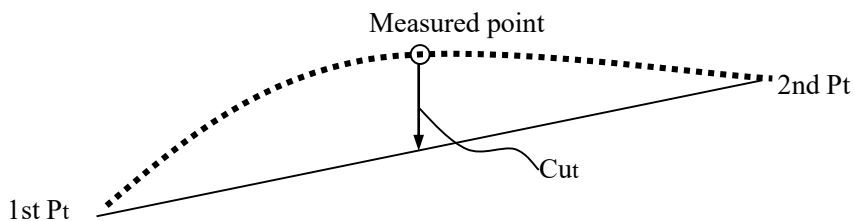

Offline: A positive value indicates the point is on the right of the baseline and a negative value

indicates it is on the left.

Cut: indicates that the point is below the baseline.

Fill: indicates that the point is above the baseline.

Length: distance along the baseline from 1st point to the measured point.

【Procedure of stake out line/line】

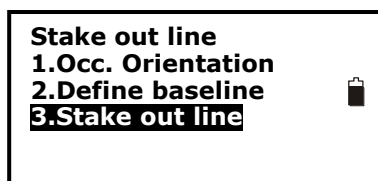

1. Select "3. Stake out line" after defining a baseline.

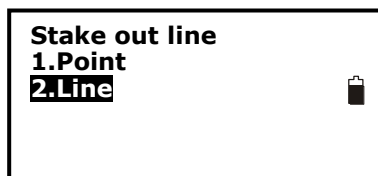

2. Select "2.Line".

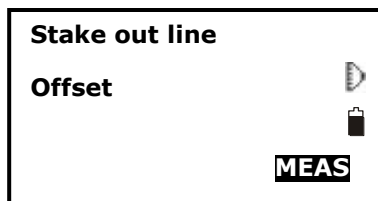

3. Input offset value: the horizontal move distance of baseline, right side indicates positive value and left side indicates negative value. Go to step 4 without inputting.

4. Aim at the target and press F4: [MEAS] to measure. The measured results are displayed.

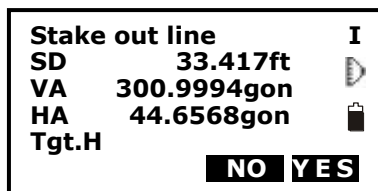

5. Press F3: [NO] to re-measure the target.

Press F4: [YES] to use the measured values. The difference between the measured data and the baseline displays:

Offline: A positive value indicates the point is on the right of the baseline and a negative value indicates it is on the left.

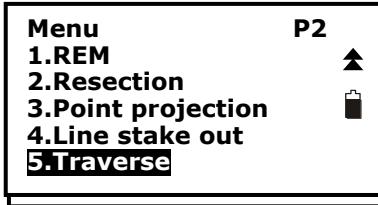

"Cut" indicates that the point is below the baseline.

"Fill" indicates that the point is above the baseline.

Length: Distance along the baseline from the first point to the measured point.

6. Aim at the next target and press F4: [MEAS] to continue the measurement.

15. Traverse Surveying

Measure the coordinate of foresight point and save it in the list, this point would be taken as the occupied point after transferring to point 2, and the previous occupied point will be taken as the backsight point, the azimuth angle will be calculated and set.

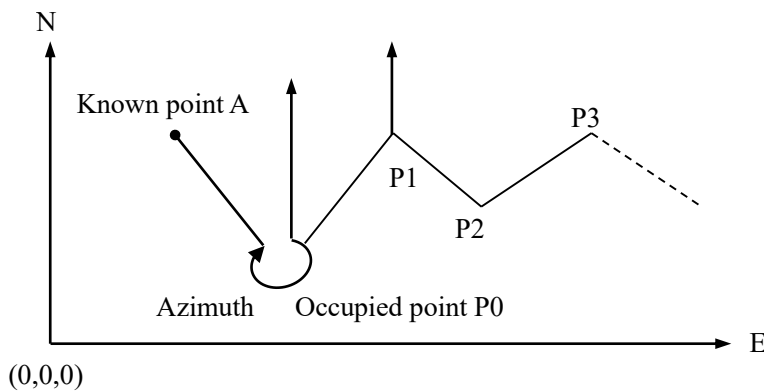

15.1 Save Coordinate

Here is the operation of how to measure the foresight point and save it in the list.

【Procedure of saving coordinate】

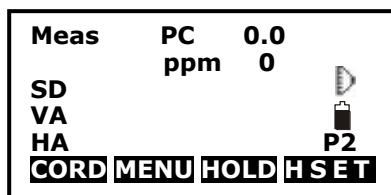

1. Press F2: [MENU] on P2 of the basic measurement mode.

2. Turn to P2, select "3.Traverse".

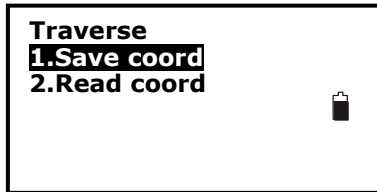

3. Press "1.Save coord".

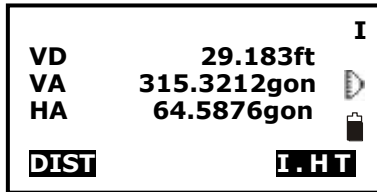

3. Aim at the target point and then press F1: [DIST]. You can press F4: [I.HT] to re-input instrument height or target height here.

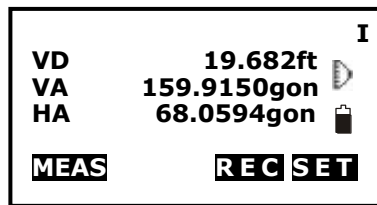

4. Press F4: [SET] to save the data, or press F3: [REC] to record it in the list.

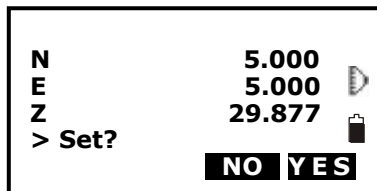

5. Press F3: [NO] back to the previous mode and press F4: [YES] to set the data.

15.2 Read Coordinate

Set the measured foresight point in the saved coordinates list as the occupied point, and the previous occupied point becomes the back point.

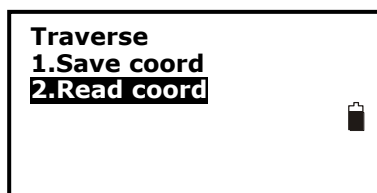

1. Move the instrument to the measured foresight point.

2. Select "2. Read coord".

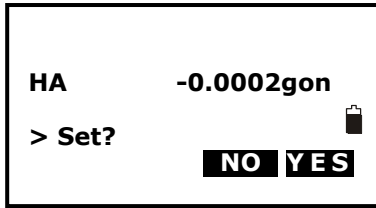

3. First aim the previous occupied point, then press F4: **[YES]** to set the previous foresight point coordinate as the occupied point coordinate or press F3: **[NO]** to give up.

16. Inverse

The distance and azimuth from a start point to an end point could be calculated according to input their coordinates.

Input:

Coordinate of start point: N0, E0, Z0

Coordinate of end point : N1, E1, Z1

Output:

Distance: D

Azimuth: Az

【Procedure of Inversing】

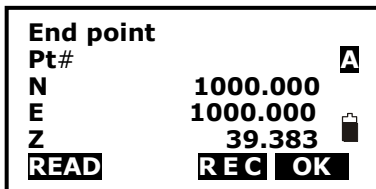
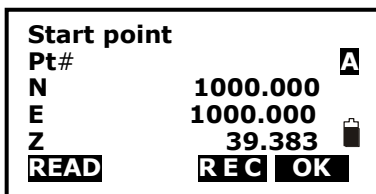
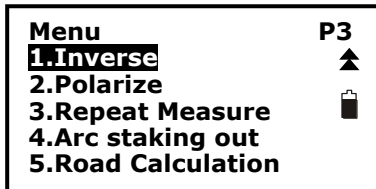

1. Press F2: **[MENU]** on P2 of the basic measurement mode.

2. Turn to P3, select "1.Inverse".

3. Input coordinates of the start point, and press F3: **[REC]** to record the data in the list if necessary. You could press F1: **[READ]** to read the existed data. Press F4: **[OK]** to set.

4. Input coordinates of the end point. See the previous step.



5. The inverted value will display. Press F3: [NEXT] to continue, press F4: [OK] back to menu mode.

17. Polar Coordinates Calculation

The coordinates of the end point could be calculated according to input azimuth, distance and the NEZ coordinates of start point.

Input:

Coordinate of start point: N0,E0,Z0

Azimuth: Az

Distance: Dist

Output:

Coordinate of end point: N1,E1,Z1

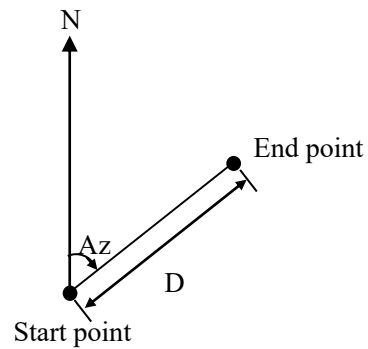

【Procedure of Polarize】

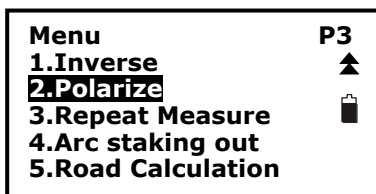

1. Press F2: [MENU] on P2 of the basic measurement mode.

2. Turn to P3, select "2.Polarize".

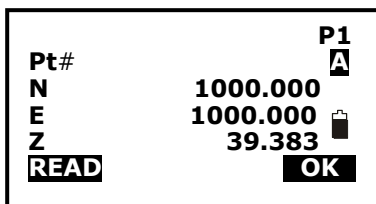

3. Input the data in corresponding items. You could press F1: [READ] to read the existed coordinate data for start point. Press F4: [OK] to enter.

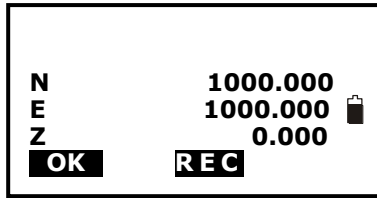

4. The calculated data displays. Press F3: **[REC]** to record it in the list, and press F1: **[OK]** back to menu mode.

18. Repetition Angle Measurement

Repetition angle measurement can be done by horizontal angle right measurement mode.

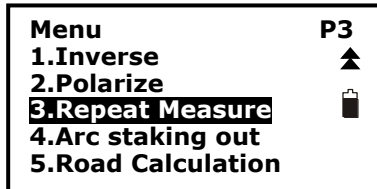

1. Press F2: [MENU] on P2 of the basic measurement mode.

1. Turn to P3, select "3.Repeat Measure".

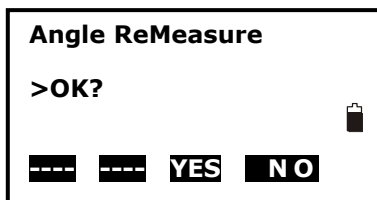

2. Press the F3: [Yes] key.



3. Collimate the target A and press the F1[OSET] key.

4. Press the F3: [Yes] key.

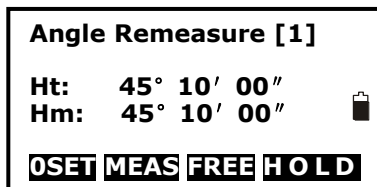

6. Collimate the target B using the horizontal clamp and tangent screw.

Press the F4: [HOLD] key.

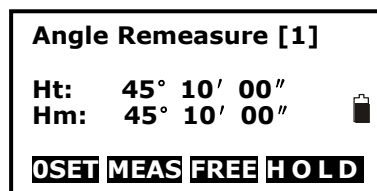

7. Recollimate the target A using the horizontal clamp and tangent screw, and press the F3:[FREE] key.

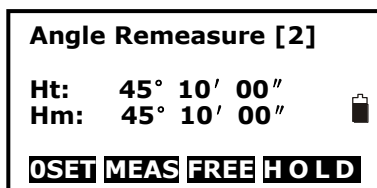

8. Recollimate the target B using the horizontal clamp and tangent screw, press the F4:[HOLD] key.

9. Repeat 7 to 8 to measure the desired number of repetition.

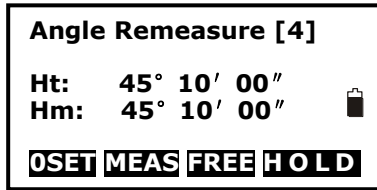

10. Press F2: [Meas] or [ESC] key to return to the normal mode.

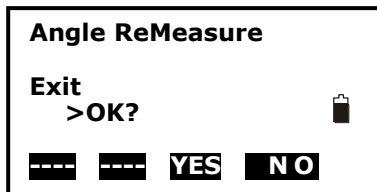

11. Press the F3:[YES] key.

NOTE:

- Horizontal angle can be accumulated up to (3600°00'00" – minimum reading) (horizontal angle right). In case of 5 second reading, horizontal angle can be accumulated up to +3599°59'55".
- Error will be displayed when the results differ from first measurement by more than $\pm 30''$.

19. Arc Staking Out Measurement

This application permits the user to define a Reference Arc by 2 points or 3 points and then stake out in relation to the arc.

19.1 Occ. Orientation

1. After power on, main interface will be presented, as shown in below figure.

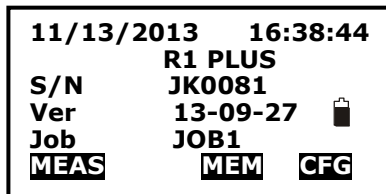

2. Press F1: **[MEAS]** to enter into basic measurement mode.

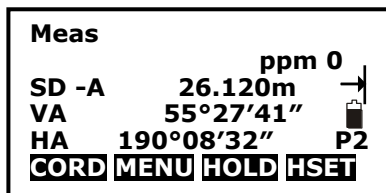

3. Press F2: **[MENU]** to enter into programs menu, then press function key "Func" and switch to Page 3(P3).

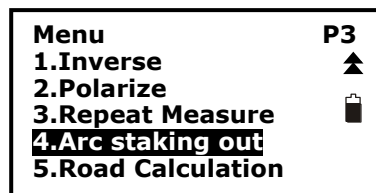

4. Next, select function key "4.Arc Staking out" to enter arc staking out menu.

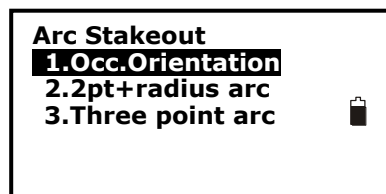

5. Select **1.Occ.Orientation** to set the station.



- ① Select **1.Occ.Coordinate** to confirm coordinate of occupied point.

Pt#	3
Inst.H	0.000m
N0 :	30.434
E0 :	5.917
Z0 :	-10.492
READ	RES REC OK

[READ]: Reads the existed coordinate as occupied coordinate.

[RES]: Determines occupied coordinate by resection.

[REC]: Records current data.

[OK]: Completes inputting.

- ② Select **2.Set H angle** to carry out orientating by "Azimuth" and "Back sight".

Set H angle
1.Azimuth
2.Back sight

19.2 2pt+Radius Arc Staking Out

- 1.On arc staking out menu select **2. 2pt+radius arc** to start 2-point arc staking out measurement.

Arc Stakeout
1.Occ.Orientation
2.2pt+radius arc
3.Three point arc

2. Input the coordinate of arc start point.

Define/Start PT	
Pt#	
Np :	4.000
Ep :	7.000
Zp :	2
READ	REC MEAS OK

[READ]: Reads the existed coordinate as start point.

[MEAS]: Determines start point by measuring.

[OK]: Sets the data.

3. Input the coordinate of arc end point.

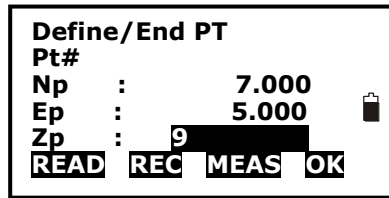

4. Input the radius of arc, press function key "ENT" to set the data.

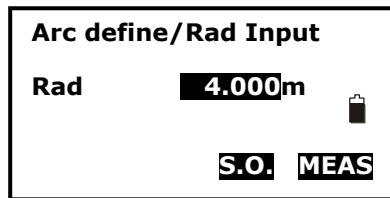

5. Decide to Measure or Stake Out

[MEAS]: Activates Line & Offset measuring.

[S.O.]: Starts the program to stake out.

1) Measure

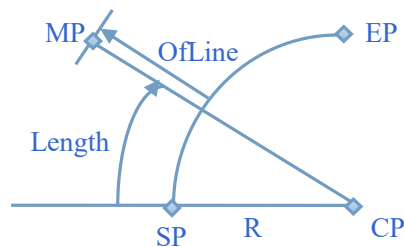

SP: Start point of arc

EP: End point of arc

CP: Centre point of circle

MP: Measured point

R: Radius of circle

Length: Distance from start of arc along with the curve

OfLine: Vertical distance from arc

Press F4: **[MEAS]** to enter into below display.

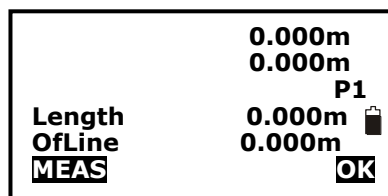

Then press F1: **[MEAS]** to measure current rod (MP), "Length" and OfLine values relative to the

arc will display, as figure shows.

↓	18.672m
▲	5.032m
	P1
Length	12.743m
OfLine	12.453m
MEAS	OK

Length: Distance from start point of arc along with the curve.

OfLine: Vertical distance from arc.

NOTE: When the arc radius is positive, if the MP has deviation, then it must be outside the arc.
When the arc radius is negative, if the MP has deviation, then it must be inside the arc.

2) S.O. function

Press F3: **S.O.** to enter "Arc define/ Input" dialog, as figure shows:

Arc define/Input	
Length	0.000m
OfLine	0.000m
E.A. E.S. Ok	

[E.A.]: Equal arc stake out

[E.S.]: Equal string stake out

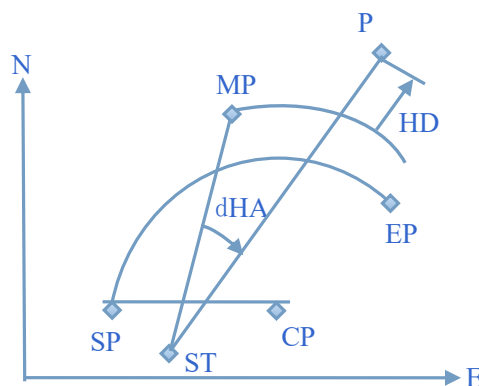

ST: Station

SP: Start point of arc

EP: End point of arc

CP: Centre point of circle

P: Point to stake out

MP: Measured point
dHA: Difference in horizontal angle
HD: Difference in distance measurement

① Normal arc stake out

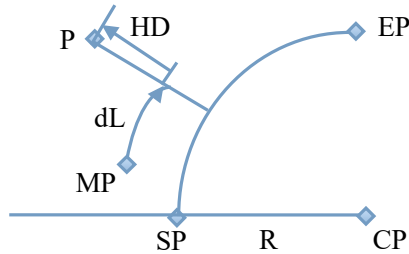

dL: Distance from MP along with the curve.
HD: Difference in distance measurement between MP and P(stake out point).

Normal arc stake out is just operated on “Arc define/ Input” dialog. This allows to stake out a point by entering a length and an OfLine.

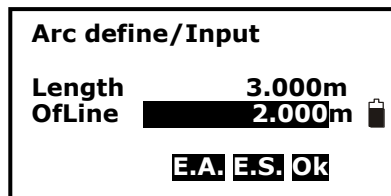

Length: Distance from start point of arc along with the curve.
OfLine: Vertical distance from arc.
Then press F4: **[OK]**, the stake out result will display as shown in below figure.

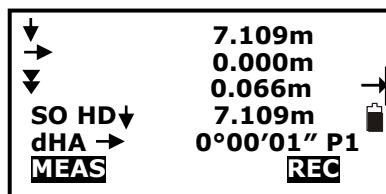

- ↓ : Represents HD in Figure 3.Indicates moving the rod (prism) in station direction.
- : Represents dL in Figure 3.Indicates moving the rod (prism) in right direction. When this value goes to “0”, the direction instrument faces is just the direction to stake out.
- ▼ : This value indicates that the rod is higher than the arc. Indicates moving the prism

downwards.

SO HD↓: Stake out HD according to the arrow direction.

dHA: Difference in horizontal angle. When this value goes to "0", the direction instrument faces is just the direction to stake out.

[MEAS]: Measure a point.

NOTE: After rotating the instrument until dHA is "0", namely, the instrument points the stake out direction, press F1: **[MEAS]** to measure. When the values of the first two lines, namely HD and dL, are "0", the stake out point is found.

② Equal arc stake out

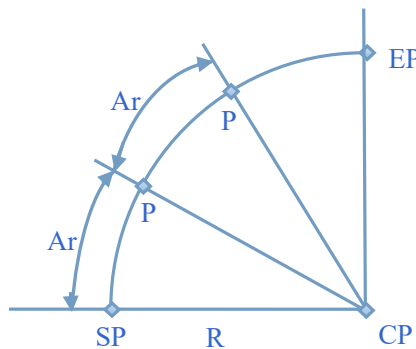

P: Point(s) to stake out

Arc: Arc length

On "Arc define/ Input" dialog, press F2:[E.A.], then input arc length and offset distance, this program completes the staking out progress by dividing the arc between start point and end point into several parts.

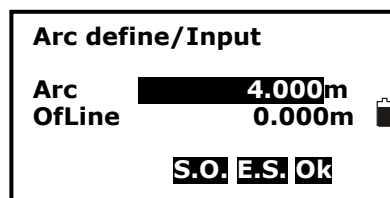

Arc: Input the length of the arc-segment which you want to stake out.

OfLine: Input the offset value here.

After pressing F4: **[OK]**, the stake out result will display.

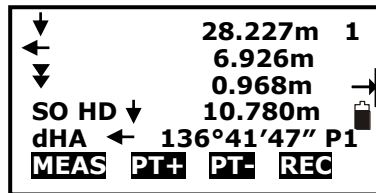

[PT +][PT -]: Toggles through the calculated stake out points. When up-right number is "0", it means start point. When up-right number is "1", it means the first equal arc point. And the rest may be deduced by analogy.

NOTE: The contents of stake out result can refer to normal arc stake out.

③ Equal string stake out

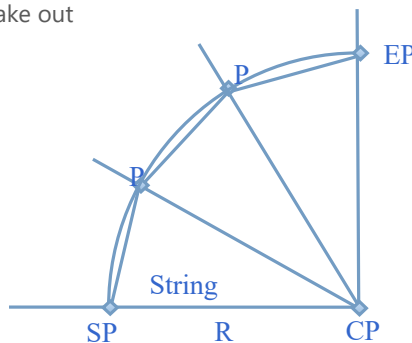

String: Chord length

On "Arc define/ Input" dialog, press F3:**[E.S.]**, then input string length and offset distance, the contents and softkey functions are the same as described in " Equal arc Stake Out " section.

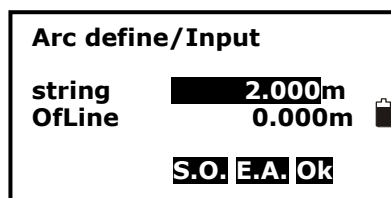

After pressing F4: **OK**, the stake out result will display.

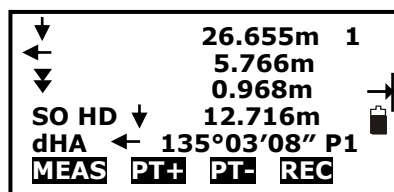

19.3 Three Point Arc Staking Out

1. On arc staking out menu select **3. Three Point Arc** to start 3-point arc staking out measurement.

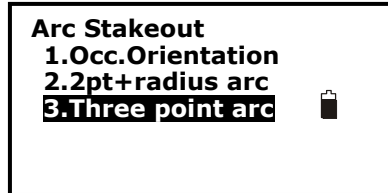

2. Input the coordinate of arc start point.

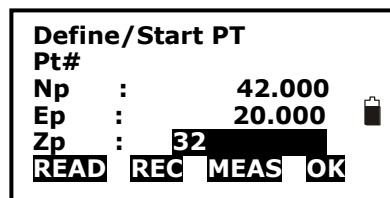

[READ]: Reads the existed coordinate as start point.

[OK]: Sets the data.

3. Input the coordinate of arc end point.

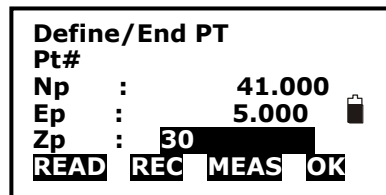

[READ]: Reads the existed coordinate as end point.

[OK]: Sets the data.

4. Input the coordinate of arc Mid point (random point on arc except start point and end point).

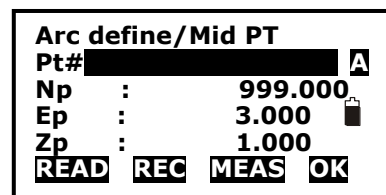

[READ]: Reads the existed coordinate as stake out coordinate

[OK]: Sets the data.

5. After step 4, it'll enter into "arc define/Input" display. Specific operations are the same as described in "**Two Point Arc Staking Out**".

20. Road Staking Out Measurement

This program is especially designed for Road Layout measurement. It can be used for horizontal curve layout. Normally one road is constituted by several elements, such as line, circle curve or Spline.

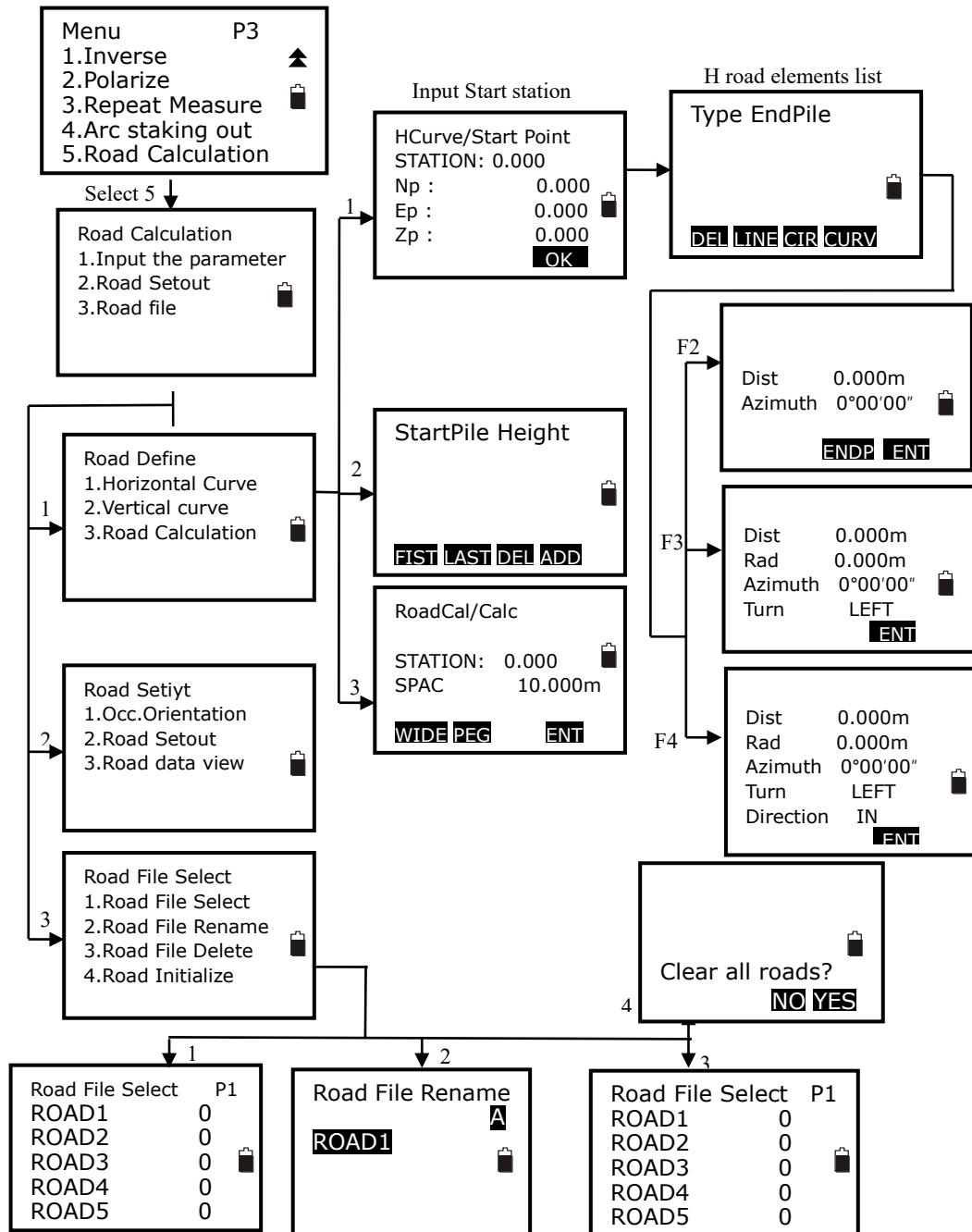

20.1 Input the Start Station

Road Calculation 1.Input the parameter 2.Road Setout 3.Road file	
---	---

1. Press F2: [MENU] on P2 of the basic measurement mode, on the page 3 select **5.Road Calculation** enter road menu.

Road Define 1.Horizontal Curve 2.Vertical curve 3.Road Calculation	
---	---

2. Select **1.Input the parameter** to enter road design menu. And then select **1.Horizontal Curve**, start point entering menu will display.

HCurve/Start Point STATION: 0.000 Np : 0.000 Ep : 0.000 Zp : 0.000 OK	
--	---

3. Enter the start point station and coordinate, press F4: [OK] key. Road horizontal elements editing menu will display.

Type EndPile DEL LINE CIR CURV	
---	---

20.2 Input Road Horizontal Elements

Three types elements can be input, including line, curve and spiral.

20.2.1 Input Line Element

Dist 100m Azimuth 0°00'00" ENDP ENT	
--	---

1. Make sure the instrument is in horizontal elements editing menu, press F2 to display line element inputting menu.

Input the line length and azimuth in the **Dist** and **Azimuth** filed. Press F4:[ENT] key to confirm.

NOTE:

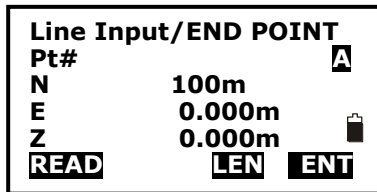

You can press F3:[ENDP] to enter the end point inputting menu.

Input the end point coordinate directly, or press F1:[READ] to recall from memory.

Press F3:[LINE] to back to the LENGTH menu

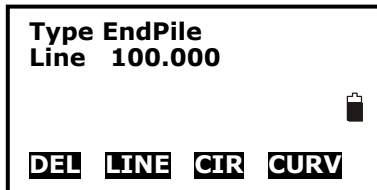

Press F4:[ENT] to confirm, you will see the line element in the list menu.

Here EndPile means the end station of this element.

20.2.2 Input Circle Element

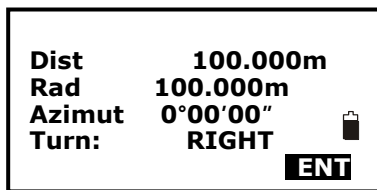

1. Make sure the instrument is in horizontal elements editing menu, press F3 to display curve element inputting menu.

Input the curve parameters, including length [Dist], radius [Rad], azimuth [Azimuth] and turn [Turn].

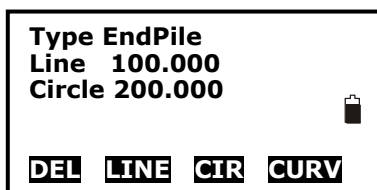

2. Press F4: [ENT] key to confirm, back to the horizontal elements menu.

Here EndPile means the end station of this element.

NOTE:

1. Normally the azimuth will calculate and display following previous element.
2. When you set the turn, move the cursor to [Turn] item, press ◀ or ▶ key to shift between Left and Right.

20.2.3 Input Spiral Element

Dist	100.000m	
Rad	100.000m	
Azimuth	57°17'44"	
Turn	RIGHT	
Direction	IN	
ENT		

1. Make sure the instrument is in horizontal elements editing menu, press F4 to display spiral element inputting menu.

Input the curve parameters, including length [Dist], radius [Rad], azimuth [Azimuth], turn [Turn] and direction

[Direction].

Type	EndPile	
Line	100.000	
Circle	200.000	
Spiral	300.000	
DEL LINE CIR CURV		

2. Press F4: [ENT] key to confirm, back to the horizontal elements menu.

Here EndPile means the end station of this element.

NOTE:

1. Normally the azimuth will calculate and display following previous element.
2. When you set the turn or direction, move the cursor to [Turn] or [Direction] item, press ◀ or ▶ key to shift the options.
3. If you set the Direction is IN, here the inputted Rad is End radius of spiral, its start radius is default as ∞; if you set the direction is OUT, here the inputted is start radius of spiral, its end radius is default as ∞.

20.2.4 Road Horizontal Element Editing

In the horizontal element editing menu, the inputted element can be edited.

Type	EndPile	
Line	100.000	
Circle	200.000	
Spiral	300.000	
Circle	400.000	
DEL LINE CIR CURV		

- Delete horizontal element

1. Move ▲ or ▼ key, the cursor will move to different element.

Type	EndPile	
Line	100.000	
Circle	200.000	
Spiral	300.000	
Circle	400.000	
DEL LINE CIR CURV		

2. Press F1: [DEL] to delete the selected element, the two elements adjacent with deleted one will connect automatically.

```

Type   EndPile
Line   100.000
Spiral 200.000
Circle 300.000
Spiral 400.000
DEL  LINE  CIR  CURV
    
```

```

Type   EndPile
Line   100.000
Spiral 200.000
Circle 300.000
Spiral 400.000
DEL  LINE  CIR  CURV
    
```

```

Dist    200.000m
Rad     100.000m
Azimuth 0°00'00"
Turn    RIGHT
Direction IN
ENT
    
```

```

Type   EndPile
Line   100.000
Spiral 300.000
Circle 400.000
Spiral 500.000
DEL  LINE  CIR  CURV
    
```

```

Road Define
1.Horizontal Curve
2.Vertical curve
3.Road Calculation
    
```

- Edit horizontal element

1. Move ▲ or ▼ key, the cursor will move to different element.

2. Press ENT key to edit the selected element.

3. Press F4:[ENT] key to confirm, other elements following the edited one will upgrade automatically.

4. After all the horizontal elements are confirmed, press [ESC] key back to previous menu.

20.3 Input Road Vertical Elements

Road vertical elements is confirmed by some intersection points, you should input same parameters for the intersection points, including station, height, and length from this intersection point to next intersection point.

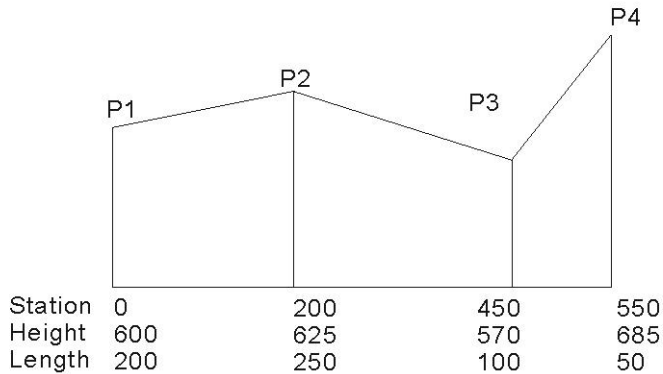

20.3.1 Input Vertical Road Element.

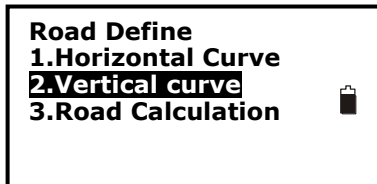

1. Make sure the instrument is in Road Define menu, select
2. Vertical Curve to vertical elements editing menu.

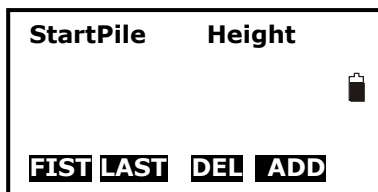

Here:

Press F1:[**FIST**] key, the cursor will move to the first element.

Press F2:[**LAST**] key, the cursor will move to the last element.

Press F3:[**DEL**] key to delete the selected element.

Press F4:[**ADD**] key to add a new vertical element.

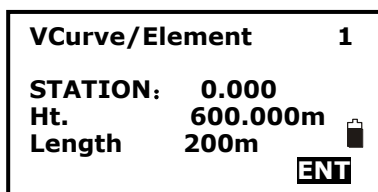

2. Press F4 to display Vertical road element inputting menu. Input the parameter for vertical element.

Press F4:[**ENT**] key to confirm.

StartPile	Height
0.000	600.000

F1ST
LAST
DEL
ADD

3. You will see the just inputted element in the vertical element editing menu.

VCurve/Element	
STATION	200.000
Ht.	625.000
Lengh	250

ENT

4. Press F4:[ADD] to input next one.

Here the STATION is displayed automatically, it comes from the previous element's length.

Press F4: key to confirm.

StartPile	Height
0.000	600.000
200.000	625.000
400.000	570.000
550.000	700.000

F1ST
LAST
DEL
ADD

5. Repeat step 4 to input all the vertical elements for the road.

20.3.2 Edit Vertical Road Element

In the horizontal element editing menu, the inputted element can be edited.

StartPile	Height
0.000	600.000
200.000	625.000
400.000	570.000
500.000	685.000

F1ST
LAST
DEL
ADD

- Delete vertical element

1. Move F1: [F1ST], F2:[LAST], ▲ or ▼ key, the cursor will move to different element.

StartPile	Height
0.000	600.000
200.000	570.000
300.000	685.000

F1ST
LAST
DEL
ADD

2. Press F3: [DEL] to delete the selected element, the two elements adjacent with deleted one will connect automatically.

For example, after delete the second element, the vertical road curve figure is shown below:

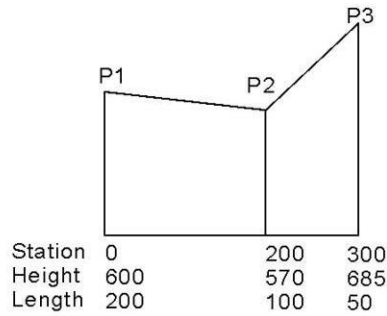

• Edit horizontal element

StartPile	Height
0.000	600.000
200.000	625.000
400.000	570.000
500.000	685.000
FIST	LAST
DEL	ADD

1. Move ▲ or ▼ key, the cursor will move to different element.

VCurve/Element	
STATION:	200.000
Ht.	625.000
Length	180 m
ENT	

2. Press ENT key to edit the selected element.

StartPile	Height
0.000	600.000
200.000	625.000
380.000	570.000
480.000	685.000
FIST	LAST
DEL	ADD

3. Press F4: [ENT] key to confirm, other elements following the edited one will upgrade automatically.

4. After all the horizontal elements are confirmed, press [ESC] key back to previous menu.

For example, after edit the second element, the vertical road curve figure is shown below:

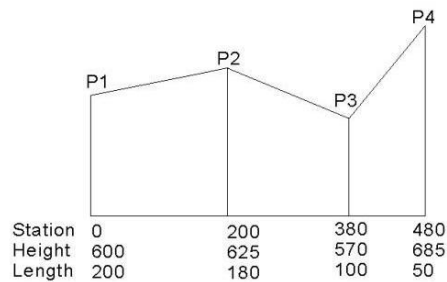

20.4 Road Calculation

20.4.1 Input the road width element

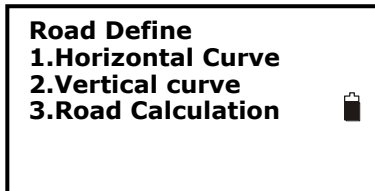

1. Make sure the instrument is in Road Define menu, select **3. Road Calculation**

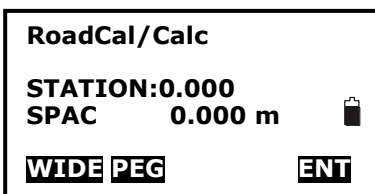

2. Press F1: **[WIDE]** to road width setting menu.

Press F1: **[FIST]** key, the cursor will move to the first element.

Press F2: **[LAST]** key, the cursor will move to the last element.

Press F3: **[Del]** key to delete the selected element.

Press F4: **[ADD]** key to add a new vertical element.

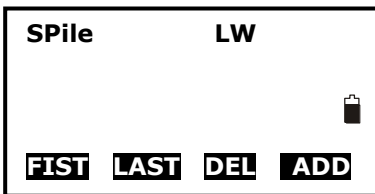

3. Press F4: **[ADD]** to enter road wide inputting menu.

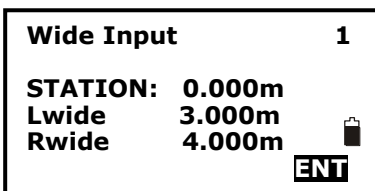

4. Input the parameters of road width.

STATION: the road will take this width begin from this point to next road width element

Lwide: left width

Rwide: right width

Press F4: **[ENT]** key to confirm.

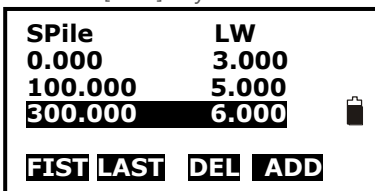

5. Repeat step 4 to input other road width.

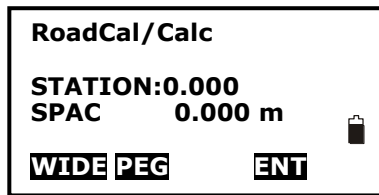

6. Press **[ESC]** back to road calculation menu.

20.4.2 Additional Station Setting

Some special stations can be calculated and stake out, the setting procedures are same with road width element inputting, but their result are different; for road width element, the inputted parameters are available from setting station to next element, but for additional station setting, the inputted parameters are available only for setting station.

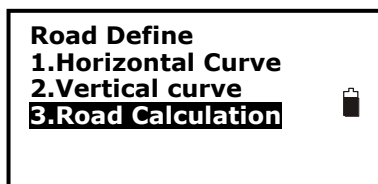

1. Make sure the instrument is in Road Define menu, select **3.Road Calculation**

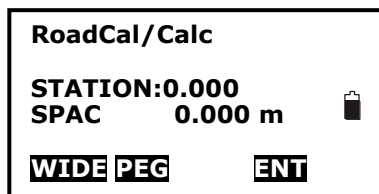

2. Press F2:**[PEG]** to enter additional station setting menu.

Press F1:**[FIST]** key, the cursor will move to the first element.

Press F2:**[LAST]** key, the cursor will move to the last element.

Press F3:**[Del]** key to delete the selected element.

Press F4:**[ADD]** key to add a new vertical element.

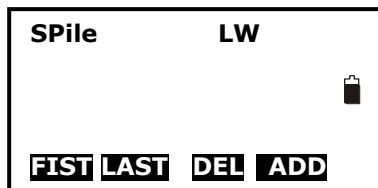

3. Press F4:**[ADD]** to enter road wide inputting menu.

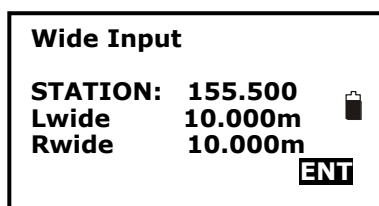

4. Input the parameters of road width.

STATION: the road will take this width begin from this point to next road width element

Lwide: left width

Rwide: right width

Press F4: **[ENT]** key to confirm.

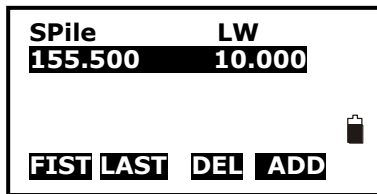

5.Repeat step 4 to input other road width.

6. Press [ESC] back to road calculation menu.

20.4.3 Road Calculation

After design the road, input the interval to calculate the staking points.

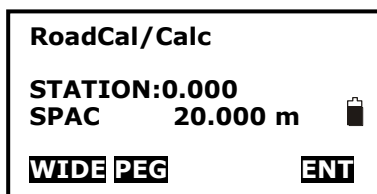

1. Input the interval of staking points on the road.

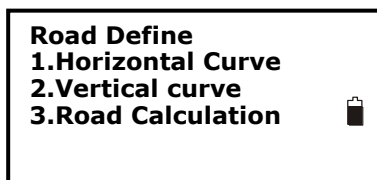

2. Press F4: [ENT] to calculate, "calculating" will display until "Cal complete" appear, the program go back to previous menu automatically.

NOTE:

If following display, it means there are some staked points exist in this file already. Press F3: [YES] key to cover these points, or press F4:[NO] back to previous screen.



20.5 Road Staking Out Data View

After design and calculate the road, all the staking points can be view.

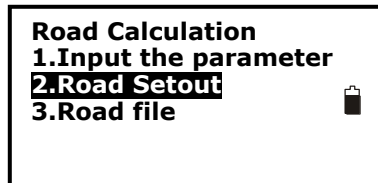

1. Press F2: [**MENU**] on P2 of the basic measurement mode, on the page 3 select **5.Road Calculation** enter road menu.

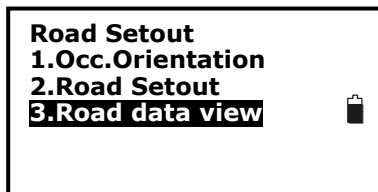

2. Select **2.Road Setout** to road setout menu.

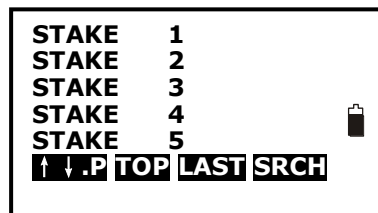

3. Select **3.Road data view** to view the staking station data, the station list will display.

Here:

STAKE: Center station serial number

RSTAKE: Right station serial number

LSTAKE: Left station serial number

Press F1: [↑ ↓ .P] key to change the function of ▲ and ▼ keys, if it is light, press ▲ or ▼ to move cursor between adjacent points. If it is backlight display, press ▲ or ▼ key to move cursor to display adjacent pages.

Press F2: [**TOP**] key to move cursor to first station.

Press F3: [**LAST**] key to move cursor to last station

Press F4: [**SRCH**] key to enter the serial number (PT#) to look for the station.

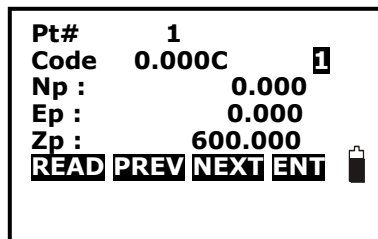

4. Press F4: [ENT] to display the coordinate of selected station.

PT#: Station serial number

Code: Station mileage, "C" means center station, "R" means right station, "L" means left station.

Press F1: [**NEXT**] key to display next station.

Press F2: [**PREV**] key to display previous station.

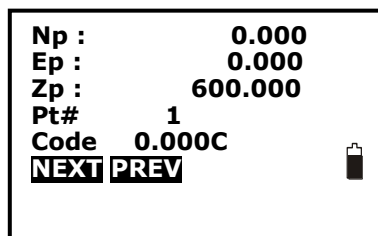

20.6 Road Stake Out

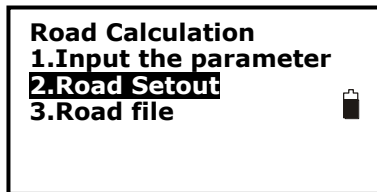

1. Press F2: [MENU] on P2 of the basic measurement mode, on the page 3 select **5.Road Calculation** enter road menu.

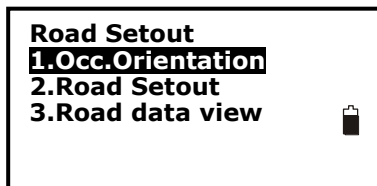

2. Select **2.Road Setout** to road setout menu.

At road setout menu select **2.Road file** to road setout menu, select **1.Occ.Orientation** to set the station and backsight.

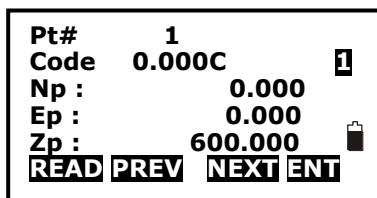

3. Select **2.RoadSetout** to stake out road, the first center station of road will display.

Here:

PT#: Station serial number

Code: Station mileage, "C" means center station, "R" means right station, "L" means left station.

Press F1: [READ] key to open the station list.

Press F2: [PREV] key to display previous station..

Press F2: [NEXT] key to display next station.

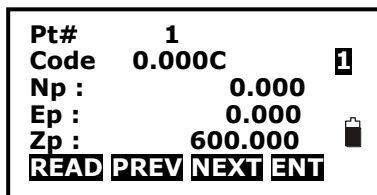

4. Press F4: [ENT] to enter coordinate staking out screen, see chapter "7.2 Coordinates Stake out Measurement" to do that.

20.7 Road File Management

20.7.1 Select a Road File

All the elements you inputted and the staking data you calculated are recorded in the current road file. You can select other file to define other road, normally one file includes one road.

NOTE:

- ◆ There are 10 road files in total, the factory default setting is "ROAD1".
- ◆ The default names are "ROAD1", "ROAD2"... "ROAD10", you can rename them if necessary.

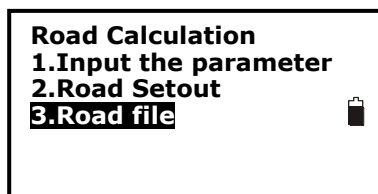

Procedures:

1. Press F2: [MENU] on P2 of the basic measurement mode, on the page 3 select **5.Road Calculation** enter road menu.

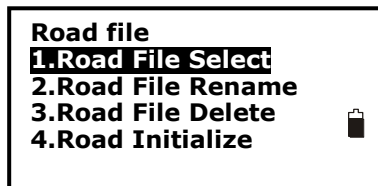

2. Select **3.Road file** to road file management menu.

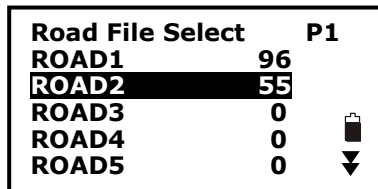

3. Select **1.Road File Select** to display road file list, the cursor will stay on current Job file.

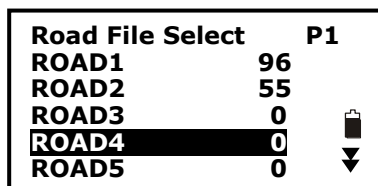

4. Press ▼ or ▲ arrow key to move cursor, after reach to the job you want to select, press [ENT] key to confirm. The program will back to road file management menu automatically.

20.7.2 Rename a Road File

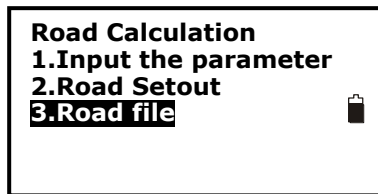

Procedures:

1. Press F2: [MENU] on P2 of the basic measurement mode, on the page 3 select **5.Road Calculation** enter road menu.

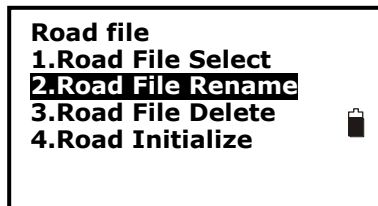

2. Select **3.Road file** to road file management menu.

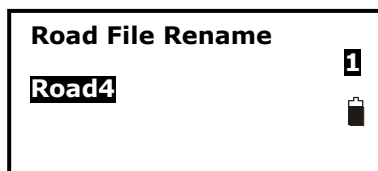

3. Select **2.Road File Rename**, current road file will display.

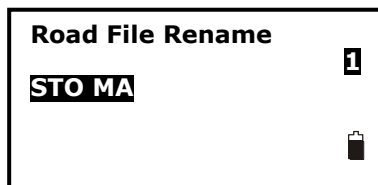

4. Input new name, press [ENT] key to confirm. The program will back to road file management menu automatically.

NOTE:

The max length of road file name is 8 characters, special symbols cannot be accepted, such as "#, ? /....."

20.7.3 Delete a Road File

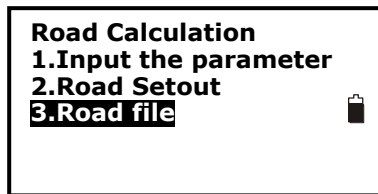

Procedures:

1. Press F2: **[MENU]** on P2 of the basic measurement mode, on the page 3 select **5.Road Calculation** enter road menu.

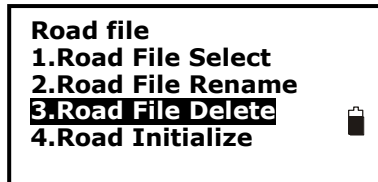

2. Select **3.Road file** to road file management menu.

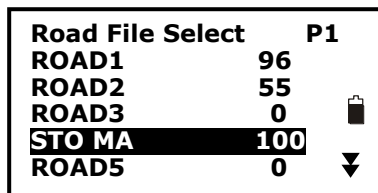

3. Select **3.Road File Delete**, road file list will display.



4. Press ▼ or ▲ arrow key to move cursor, after reach to the job you want to delete, press **[ENT]** key, it will ask you to confirm to delete, press F3:**[NO]** back to file list, the file will not be deleted.

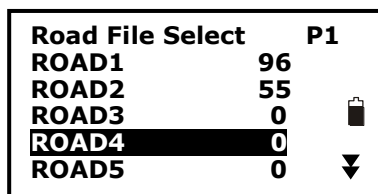

5. Press F4:**[YES]** to delete this file, all the inputted and calculated data in this file will be cleared, and the file name change to initial status.

20.7.4 Delete all Road Files

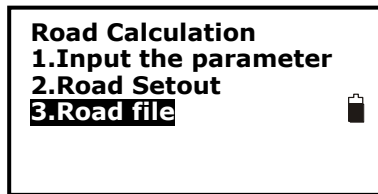

Procedures:

1. Press F2: [MENU] on P2 of the basic measurement mode, on the page 3 select **5.Road Calculation** enter road menu.

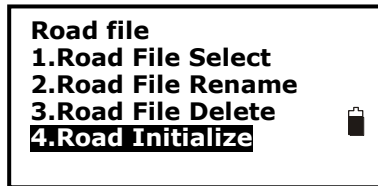

2. Select **3.Road file** to road file management menu.



3. Select **4.Road Initialize**. it will ask you to confirm to clear all roads, press F3:[NO] back to road file management menu, no file is deleted.

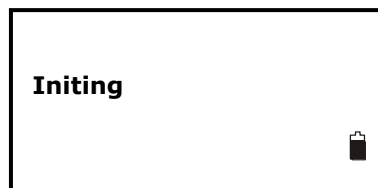

4. Press F4:[YES] to delete all road files, Initing will display, at last it will back to road file management menu automatically.

NOTE:

Pay more attention to this operation, after initialization, all the files back to initial status, the deleted elements and data can not be resumed.

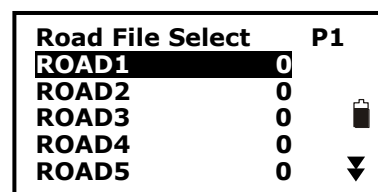

21. Record

You can record measured data, occupied data and notes into the active JOB. The memory is 60000 points in total.

21.1 Record Occupied Data

You can input occupied data into the active JOB. The record items include: occupied coordinates, point number, instrument height, code, user, date, time, weather, wind, temperature, air pressure and ppm. If the current occupied data have not been recorded in the active JOB, the previous occupied data will be used as the active one.

【 Procedure of recording occupied data 】

Meas	PC	0.0	
	ppm	0	
SD			
VA	302.5432gon		
HA	0.0000gon	P3	
EDM	OCC	OFST	REC

1. Press F4: [REC] on P3 in basic measurement mode to enter into record mode. The active JOB will display.

REC	JOB1	P1
1.Occ. data		
2.Angle data		
3.Collect Points		
4.Note		
5.View		

2. Select "1. Occ. data" to set occupied station.

REC	JOB1	P2
1.JOB select		

3. You can input the following items by hand: PT#, instrument height(Inst.H), code, N0-E0-Z0, , user, date, time, weather, wind, temperature, pressure, and ppm. Press key "▲"/"▼" to select item or press [FUNC] to turn page.

Pt#	J2	
Inst.H	0.000m	▼
N0:	0.000	
E0:	0.000	
Z0:	0.000	
READ	RES	REC OK

Press F1:[READ] to read coordinate from memory. See "\$6.1 Input the occupied point data".

Press F2:[RES] to enter resection program and get the station coordinate

Press F3:[REC] to record the station coordinate into memory.

Code	ROAD	▼
User	MA	▼
Date	:08/08/2006	
Time	:10:00:00	
Weather	:Fine	
RES	REC	OK

At the page 2 of station setting screen, press F1: [0PPM] to set ppm value as 0 directly.

4. Press F1: [OK] to set the station coordinate.

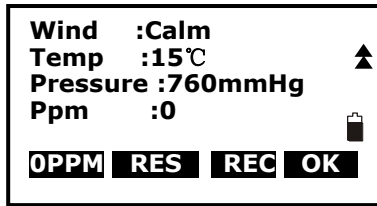

5. Set the backsight information, and back to Rec menu.

NOTE

- The max length of Pt# is 14 characters.
- The instrument height range: -9999.999~9999.999.
- The max length of code and user is 16 characters.
- Date and time are not allowed to change here.
- Weather options: Fine, Cloudy, Flurry, Rain, Snow.
- Wind options: Calm, Gentle, Light, Strong, Gust.
- The temperature range: -30 ~ 60°C.
- The pressure range: 500 ~ 1400 hPa (mbar) / 375 ~ 1050 mmHg /14.8~41.3 inch Hg/ 7.3~20.3 Psi.
- The ppm range: -499 ~ 499 ppm.

21.2 Collect Angle Data

```

Meas   PC   0.0
        ppm  0
SD
VA     302.5432gon
HA     0.0000gon   P3
EDM   OCC   OFST  REC
  
```

1. Enter into record mode. The active JOB will display.

```

REC   JOB1   P1
1.Occ. data
2.Angle data
3.Collect Points
4.Note
5.View
  
```

2. Select "2. Angle data", then aim at the target, the angle will display in real time.

```

REC   Free 44000   II
VA     148.7080gon
HA     352.4228gon
Pt#    PP01       P1
AUTO  OSET       REC
  
```

3. Press F4: [REC] to input the following items: point number, target height and code, press F1: [OK] to save data. You could press F1: [AUTO] to perform this process directly if PT#, code and tgt.H are unnecessary to re-set.

Press F2: [OSET] to set horizontal angle as 0

```

REC   Free 44000
Tgt.H          1.45ft
Code   NO
        P2
AUTO  OSET       REC
  
```

4. Repeat step 3 to collimate and collect other points angle data..

21.3 Collect Points

【Procedure of recording coordinate and distance data】

```

Meas   PC   0.0
        ppm  0
SD
VA     302.5432gon
HA     0.0000gon   P3
EDM   OCC   OFST  REC
  
```

1. Press F4: [REC] on P3 in basic measurement mode to enter into record mode. The active JOB will display.

```

REC   JOB1   P1
1.Occ. data
2.Angle data
3.Collect Points
4.Note
5.View
  
```

2. Select "3. Collect Points".

```

REC   Free 43997
N           5.000
E           5.000
Z           5.000
Pt#   D10           P1
AUTO DIST OFST REC
  
```

3. Aim at the target and press F2: [DIST] to measure distance, and then [REC] will display at the last line, press F4: [REC] to input the following items: point number, target height and code, press F1: [OK] to save data.

```

REC   Free 43997   I
SD           5.000m
VA          302.5432gon
HA           0.0000gon
Pt#   D10           P1
AUTO DIST OFST REC
  
```

You could press F1: [AUTO] to perform this process directly if PT#, code and tgt.H are unnecessary to re-set.

```

REC   Free 43997

Code S
Tgt.H          45.000m
P2
AUTO DIST OFST REC
  
```

4. Aim at other targets, repeat step 3 to collect other points.

NOTE:

- After performing the process once, both distance measurement data and coordinate data are recorded into memory as the same Pt#.
- Measured distance and coordinate data are recorded simultaneously.
- Press [FUNC] key, the screen will switch between coordinate mode and distance mode.

21.4 Record Note

【Procedure of recording note】

```

Meas   PC   0.0
        ppm  0
SD
VA     302.5432gon
HA     0.0000gon   P3
EDM OCC OFST REC
  
```

1. Press F3: [REC] on P3 in measure mode to enter into record mode. The active JOB will display.

```

REC   JOB1   P1
1.Occ. data
2.Angle data
3.Collect Points
4.Note
5.View
  
```

2. Select "5. Note".

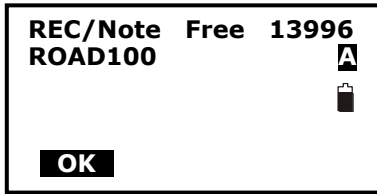

3. Input note and press F1: [OK] to save. The max length is 60 characters.

NOTE:

Max note length is 60 characters.

21.5 View Data

【Procedure of view data】

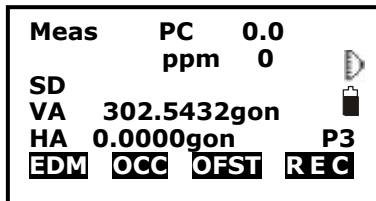

1. Press F3: [REC] on P3 in measure mode to enter into record mode. The active JOB will display.

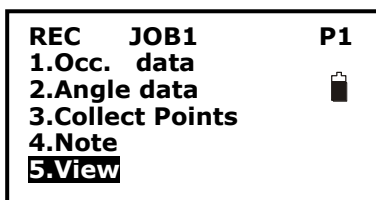

2. Press Func key to turn to page 2, Select "1. View".

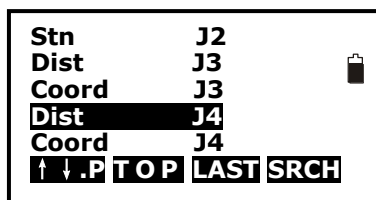

3. All recorded data of the active JOB will display,

Press F1:[↑↓.P] key to change the function of ▲ and ▼ keys, if it is light, press ▲ or ▼ to move cursor between adjacent points. If it is back light, press▲ or ▼ key to move cursor to display adjacent pages.

Press F2:[TOP] key to move cursor to first point..

Press F3:[LAST] key to move cursor to last point

Press F4:[SRCH] key to enter the serial number(PT#) to look for the point.

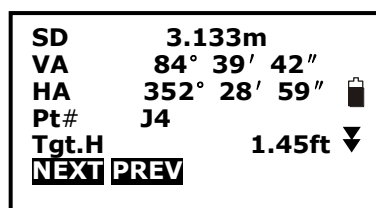

4.Select one and press key {ENT} to view, press [ESC] back to list.

NOTE:

- If the point number is the same, only the newer recorded data could be viewed.
- The data inputted beforehand could be viewed here.

21.6 Select job

【Procedure of job select】

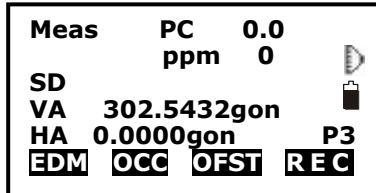

1. Press F3: [REC] on P3 in measure mode to enter into record mode. The active JOB will display.

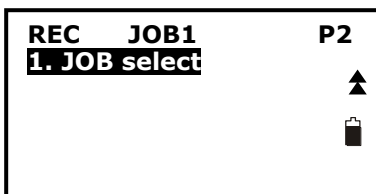

2. Press Func key to turn to page 2, Select 2.JOB select to set job, see "22.1 Select a JOB" to operate.

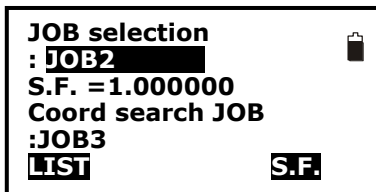

22. JOB Management

22.1 Storage Media Select

For R1 series, SD card slot is an standard equipment, user can record the measured data in internal memory or SD card directly. Before your work, it is necessary select appropriate storage media. For both memory, the file management procedures are same.

【Procedure of storage select】

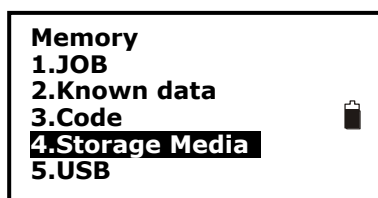

1. Select [MEM] in the status mode to enter into memory management.

2. Select "4. Storage Media Select" to enter storage media setting screen.

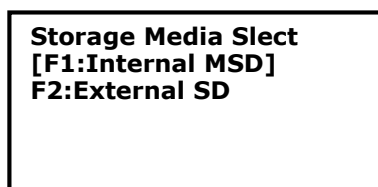

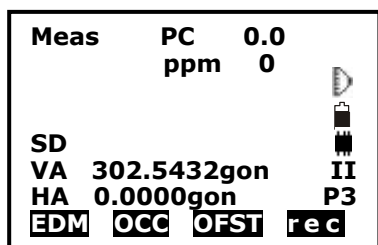

3. Press F1: Internal MSD to set the internal card as current storage media.

Or press F2: External SD to set the external SD card as current storage media.

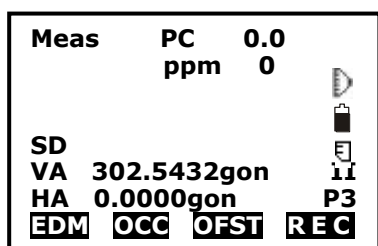

If the internal card is current storage media,  will display on screen right.



If the external SD card is current storage media,  will display on screen right.

NOTE

1. If the SD card is first using on the total station, when select it as storage media, "Initialing" will

take about 30s.

2. If there is no SD card in the card slot, if you select F2:External SD, <NO SD CARD> will display.
3. At power on mode, if you insert or pull out the SD card, <SD INSERT> or <SD is pulled out> will display, but these operations are not recommended.
4. All the menu for internal memory or external SD card are same.

22.2 Select a JOB

The active JOB or coordinate search JOB could be selected. The data (known data, measured data, occupied data, coordinates, note, etc) are recorded in the active JOB, and user is able to search and read coordinate in the coordinate search JOB when coordinate measuring, resection or stake out.

NOTE:

- There are 20 JOBS in total, the factory default setting is "JOB1".
- The default names are "JOB1","JOB2"... "JOB20", you can rename them if necessary.
- Scale factor could be set for every JOB, but only the one of the active JOB could be modified.

Here is the equation used to calculate the data: $HD2=HD1 \times S.F.$

Where, HD2: corrected horizontal distance

HD1: measured horizontal distance

S.F. : scale factor

【 Procedure of JOB selection and scale factor setting 】

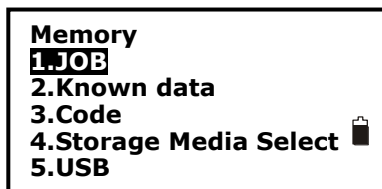

1. Press F3: [MEM] in the status mode to enter into memory management.

2. Select "1. JOB" to enter JOB management.

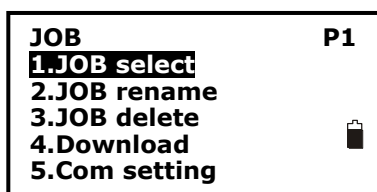

3. Select "1. JOB select" to set an active JOB and a coordinate search JOB.

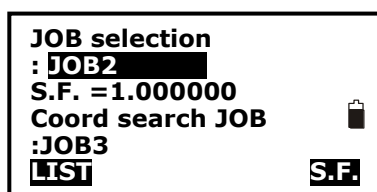

4. Press F1: [LIST] to display all JOBS on three pages.

Press F4: [S.F.] to modify the scale factor.

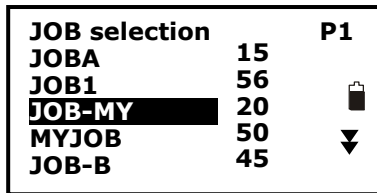

5. Select an active JOB. The numbers to the right represent the number of data items in each JOB. Press key {ENT} to save the setting.

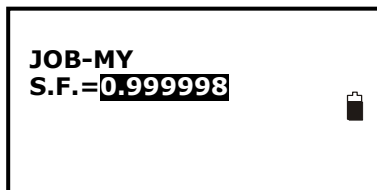

6. Input the scale factor if necessary. The range: 0.5000000 ~ 2.000000, and the factory setting is 1.000000.

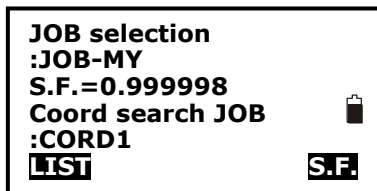

7. Select a coord search JOB following above steps 4 and 5.

22.3 Rename a JOB

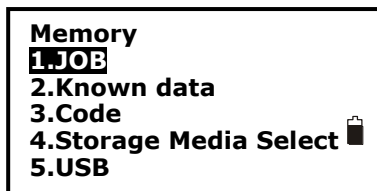

1. Press F3: [MEM] in the status mode to enter into memory management.

2. Select "1. JOB" to enter JOB management.

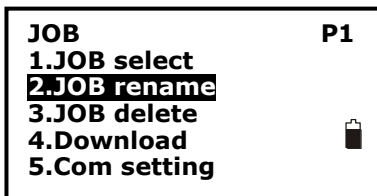

3. Select "2. JOB rename" to rename the active JOB.

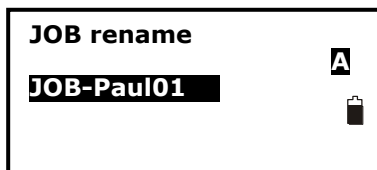

4. Input a new name and press key {ENT} to save the setting. The maximum length of a JOB name is 12 characters.

22.4 Delete a JOB

It is possible to delete an existed JOB. Once the JOB has been deleted with the recorded data cleared, the JOB name returns to the default one.

【Procedure of JOB deletion】

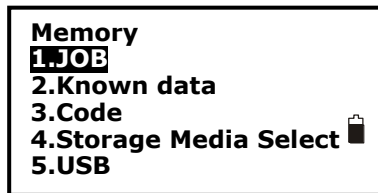

1. Press F3: **[MEM]** in the status mode to enter into memory management.

2. Select **"1. JOB"** to enter JOB management.

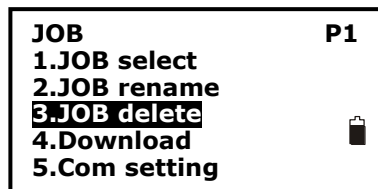

3. Select **"3. JOB delete"**.

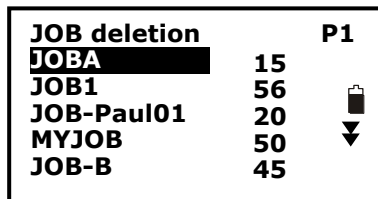

4. 20 JOBs display on three pages. The numbers to the right represent the points quantity recorded in each JOB. Select the useless JOB that you wanna delete and press key {ENT}.

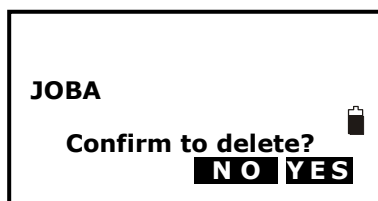

5. Press F3: **[NO]** to give up or press F4: **[YES]** to delete the JOB.

22.5 Output JOB Data

Measured data, occupied data, known point data, note and coordinates data existed in all JOBS could be outputted to PC via serial port.

NOTE:

- The software STONEX exchange is available in your CD-ROM.
- Be sure the communication port setting of instrument and PC is the same, see “§3.8.3. Communication Port Setting”, you can select **MEM/1.JOB/5.Com setting** to set the communication parameters also.

Communication Port Setting”, you can select **MEM/1.JOB/5.Com setting** to set the communication parameters also.

【Procedure of download】

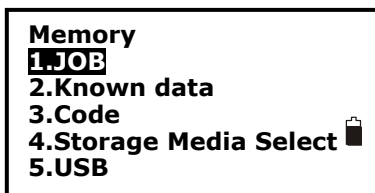

1. Select **[MEM]** in the status mode to enter into memory management.

2. Select “**1. JOB**” to enter JOB management.



3. Connect your instrument and computer via communication cable (standard component).

4. Select “**4. Download**” to enter into com output mode and all JOBS display.

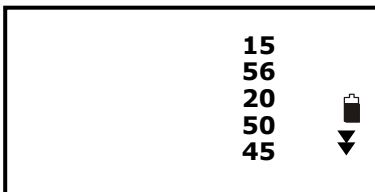

5. Select the JOB to be output.

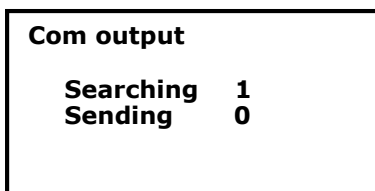

6. Press key {ENT} to start to send out via RS-232C port, it will back to JOB list mode after finishing.

More details see the Help file of STONEX Exchange, see chapter “2.1 Data transfer via RS-232C port”.

22.6 File Copy

It is possible to copy the job from current internal memory to SD card .

【Procedure of JOB copy】

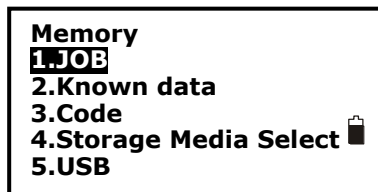

1. Select **MEM/1.JOB/6.File Copy**.



2. Press Func key to turn to page 2, Select "**1. File Copy**", the job list for current memory will display.

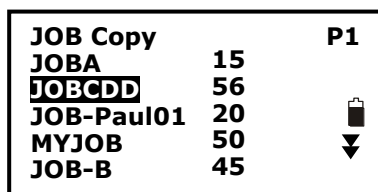

3. 20 JOBs display on three pages, select one job you want to copy. And press **[ENT]** key to confirm.

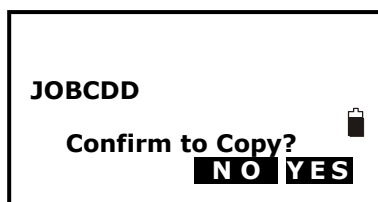

4. Press F3: **[NO]** to give up or press F4: **[YES]** to copy.

5. For more information, please read the Help file of STONEX Exchange on chapter "2.3 Data transfer via SD card".

22.7 Connect PC via USB port

R1 is equipped with USB port, you can connect it with PC for data transferring.

【Procedure of USB port connecting】

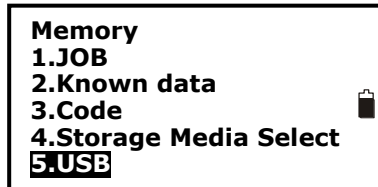

1. Select [**MEM**] in the status mode to enter into memory management.

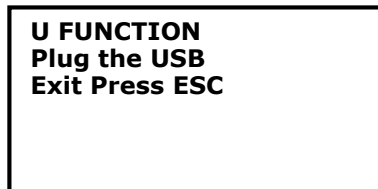

2. Select "**5.USB**" to enter USB port connecting screen.

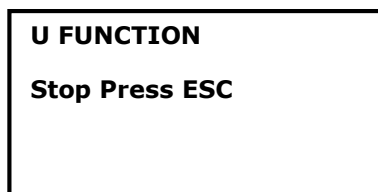

3. Connect instrument and PC via USB cable, R1 will display "U FUNCTION Stop Press ESC".

It means the R1 is connected with PC already.

Press [**ESC**] to disconnect them, and the instrument back to previous menu.

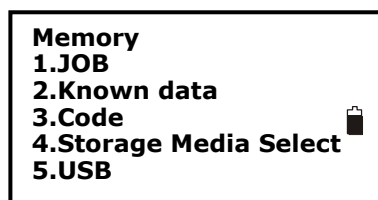

For more information to see the Help file of STONEX Exchange on chapter "2.2 Data transfer via USB slave port".

23. Known Data Management

There are 6 items in known data management.

23.1 Input Known Point Coordinate by Keys

You could input or delete coordinates of known point in the active JOB by key entry or entry from PC. The existed data you have input beforehand could be used as occupied point, backsight point, coordinates of known point or stakeout point. The memory is 60000 points in total.

【Procedure of Inputting known points coordinate】

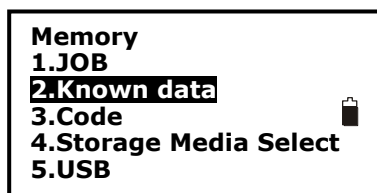

1. Press F3: [MEM] in the status mode to enter into memory management.

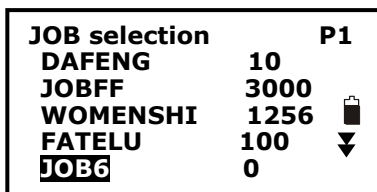

2. Select "2.Known data", job list will display. Select one Job you want to operate, press [ENT] key to confirm, known data menu will display, you can see the active JOB on the second line..

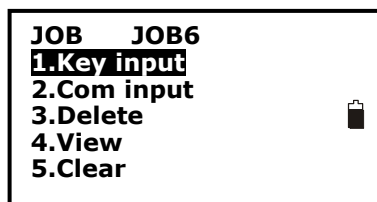

3. Select 1.Key Input.

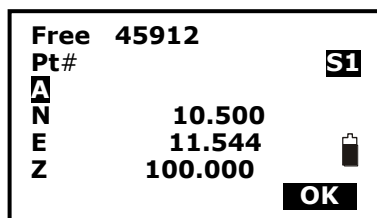

4. Input point number and coordinates. The active job and free memory is displayed at the top right corner. Press F4: [OK] to save settings and continue to input other points. Press key {ESC} back to the known data mode.

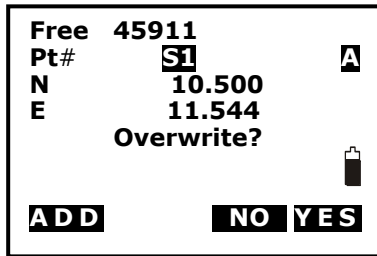

5. Once the Pt# is the same as an existed one, it will display as shown left:

Press F3: **[NO]** to re-input;

Press F4: **[YES]** to overwrite;

Press F1: **[ADD]** to save, and the original one will not Be deleted.

23.2 Input Known Point Coordinate via RS-232C

【Procedure of Inputting known points coordinate】

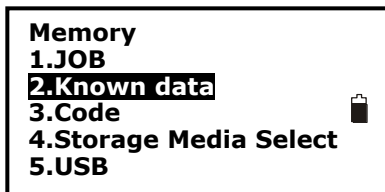

1. Connect instrument and PC via RS-232C communication cable. Press F3: **[MEM]** in the status mode to enter into memory management.

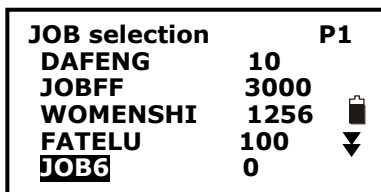

2. Select **"2.Known data"**, job list will display. Select one Job you want to operate, press **[ENT]** key to confirm, known data menu will display, you can see the active JOB on the second line..

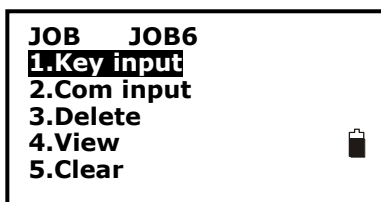

3. Select **"2.Com input"**.

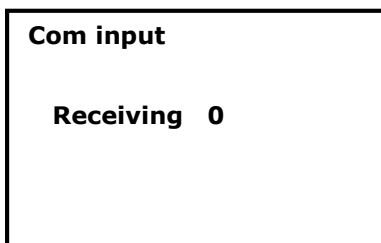

4. Run STONEX Exchange software PC, see the help file of STONEX Exchange to upload known data to current JOB, the chapter is "2.1.2 Upload Known data from PC to R1 internal memory".

When data transferring, the number following Receiving will upgrade continually, at last it will back to known data mode after finishing.

23.3 Delete known point coordinate

【Procedure of known points deletion】

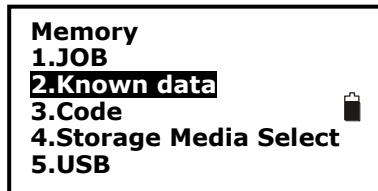

1. Press F3: [MEM] in the status mode to enter into memory management.

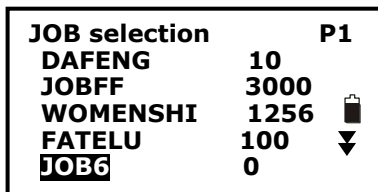

2. Select "2.Known data", job list will display. Select one Job you want to operate, press [ENT] key to confirm, known data menu will display, you can see the active JOB on the second line.

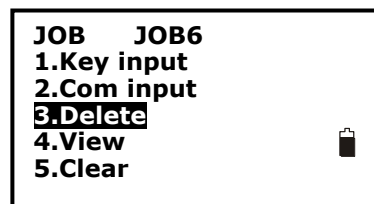

3. Select "3.Delete" and all known points in current JOB will display.

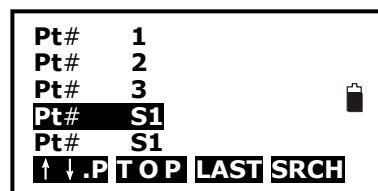

4. Select a point you want to delete, the point coordinate will display.

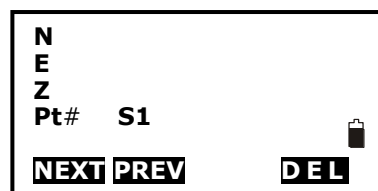

5. Press F1: [NEXT] to display the next point data;
 Press F2: [PREV] to display the previous point data;
 Press F4: [DEL] to delete it and continue to delete other points;
 Press key {ESC} back to known data management mode.

23.4 View known points data

【Procedure of known points view】

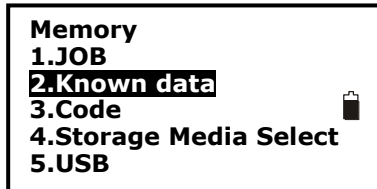

1. Press F3: [MEM] in the status mode to enter into memory management.

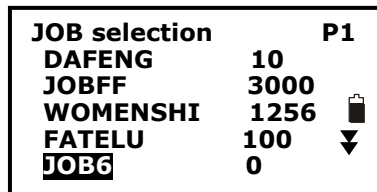

2. Select "2.Known data" , job list will display. Select one Job you want to operate, press [ENT] key to confirm, known data menu will display, you can see the active JOB on the second line..

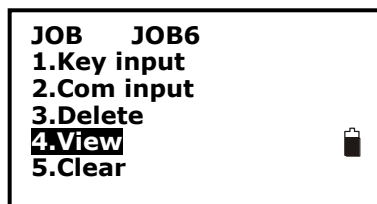

3. Select "4.View" and all known points of the current JOB will display.

4. Select a required point.

Here:

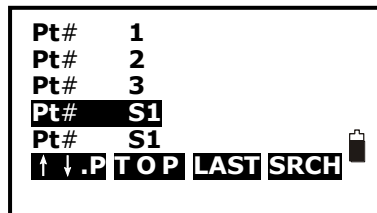

Press F1:[↑↓.P] key to change the function of ▲ and ▼ keys, if it is light, press ▲ or ▼ to move cursor between adjacent points. If it is back light, press▲ or ▼ key to move cursor to display adjacent pages.

Press F2:[TOP] key to move cursor to first point.

Press F3:[LAST] key to move cursor to last point

Press F4:[SRCH] key to enter the serial number(PT#) to look for the point.

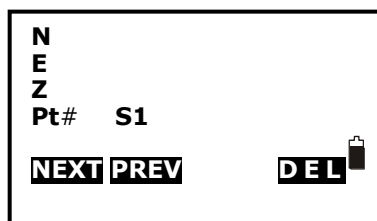

5. The coordinate and point number will display.

Press F1: [NEXT] to display the next point data;

Press F2: [PREV] to display the previous point data.

23.5 Clear all known points' data

【Procedure of clearing all known points】

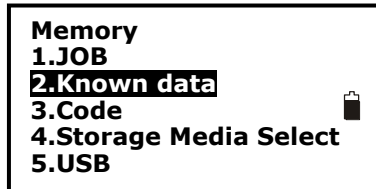

1. Press F3: **[MEM]** in the status mode to enter into memory management.

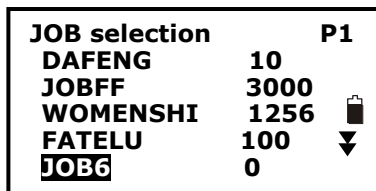

2. Select "2.Known data", job list will display. Select one Job you want to operate, press [ENT] key to confirm, known data menu will display, you can see the active JOB on the second line.

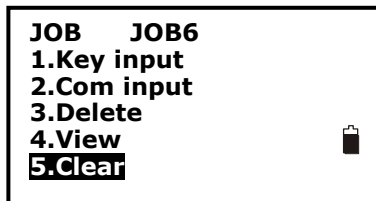

3. Select "5.Clear".

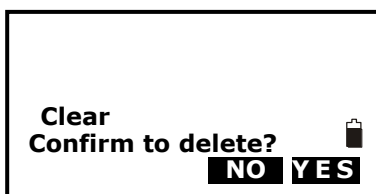

4. Press F3: **[NO]** back to known data management. Press F4: **[YES]** to delete all known points data of the active JOB completely.

24. Code Management

You could edit codes in this mode. All existed codes in memory could be read for all jobs, and the selected code could be recorded together with occupied data or measured data.

24.1 Edit Code list

【Procedure of inputting a code】

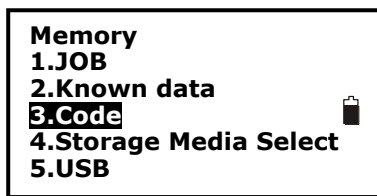

1. Select **[MEM]** in the status mode to enter into memory management.

2. Select **"3.Code"** to enter into code management.



3. Select **"1.Code Edit"**, the code will display.

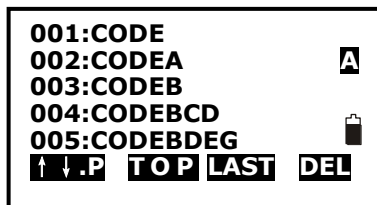

4. Press **▲** or **▼** key to move the cursor, and input or correct code.

Here:

Press F1:[**↑↓.P**] key to change the function of **▲** and **▼** keys, if it is light, press **▲** or **▼** to move cursor between adjacent codes. If it is back light, press **▲** or **▼** key to move cursor to display adjacent pages.

Press F2:[**TOP**] key to move cursor to first code

Press F3:[**LAST**] key to move cursor to last code

Press F4:[**DEL**] key to selected code.

NOTE:

- The codes recorded in memory could be read for all JOBS.
- 50 codes can be inputted.

24.2 Clear all Codes

【Procedure of clearing all codes】

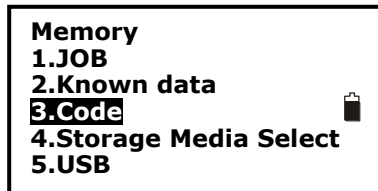

1. Press F3: [MEM] in the status mode to enter into memory management.

2. Select "3.Code" to enter into code management.



3. Select "2.Clear list".

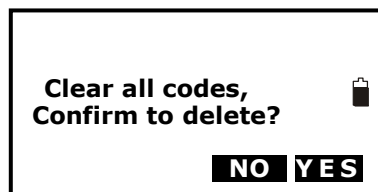

4. Press F3: [NO] back to previous mode;

Press F4: [YES] to delete all codes recorded in memory of all JOBs completely.



5. If you select "1.Code Edit", you will find no code inside.

25. Warning and Error Messages

“Low Signal!”

Please accurately re-sight the target.

“Same coordinates”

The coordinates of the backsights are the same, please re-define or re-input.

“Out of value”

The difference value of coordinates is over range

“Out of range”

The stake out height is over range.

“Need 1st obs”

During missing line measurement, the observation of the starting position was not completed normally. Sight the starting position accurately and press **[OBS]** to perform the measurement again.

“Change 1st obs?”

During missing line measurement, the observation of the target was not completed normally. Sight the target accurately and press **[MLM]** to perform the measurement again.

“Need prism obs”

During REM measuring, the observation of the target was not completed normally. Sight the offset point accurately and press **[MEAS]** to perform the measurement again.

“No Free Space!”

There is no more space to enter data. Record the data again after deleting unnecessary data from the JOB or coordinate data from memory.

“No data”

When searching for coordinate data or searching for code data, the search stopped either because the item in question does not exist or the data volume is large.

26. Check and Adjustment

26.1 The Instrument Constant

I. Check

It is suggested to observe and compare the instrument with a testing baseline which is set on stable ground with a particular accuracy, though error is not generally included in the instrument constant. If the testing line is unavailable, you can select a flat place and set up the instrument and a target in the same height.

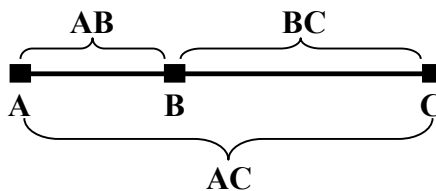

1. Select a point B on the approximately horizontal line AC with about 100 meters long. Measure the distances of lines AB , AC and BC .

2. The instrument constant can be calculated;

$$\text{instrument constant} = AB + BC - AC$$

3. Repeat steps 1 and 2 ten times, and get the average value for instrument const, if the average value is within $\pm 3\text{mm}$, adjustment is unnecessary.

4. If the difference is over $\pm 3\text{mm}$ after the preceding operations, it is necessary to reset the instrument constant.

II. Adjustment

If the instrument const is necessary to reset, please contact STONEX service representative to perform that.

26.2 Tubular Level

I. Check

1. Mount the instrument on a stable device (as tripod, adjusting device), and fix it.
2. Level the instrument until the plate level is parallel to a line linking leveling foot screws A and B, then adjust the two screws to center the bubble.
3. Turn the instrument $180^\circ/200\text{gon}$, observe the moving direction of the bubble, if it is still centered, no adjustment is necessary, if not, you have to adjust it.

II. Adjustment

1. Mount the instrument on a stable device and fix it.
2. Level it roughly.
3. Turn the instrument and make the tubular level be parallel to a line linking two leveling foot screws, then adjust the two screws to center the bubble.
4. Turn the instrument $180^\circ/200\text{gon}$, adjust the Adjusting screw with adjustment pin slightly to correct half of the bubble's displacement when it doesn't move,
5. Repeat operations 3, 4 until the bubble remains centered in any position.

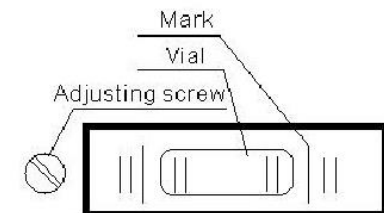

Turn the instrument 180°

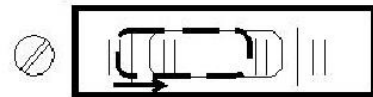

26.3 Circular Level

I. Check

1. Mount the instrument on a stable device and fix it.
2. Level it accurately by the plate level.
3. Observe the bubble of the circular level, if it is centered, no adjustment is necessary, if not, you have to adjust it.

II. Adjustment

1. Mount the instrument on a stable device and fix it.
2. Level it accurately by the plate level.
3. Adjust the three adj-screws to center the bubble by a wrench.

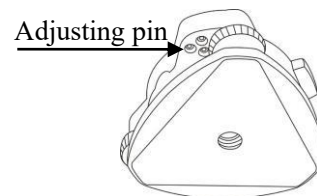
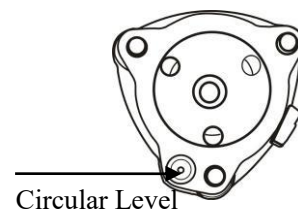

NOTE: Be careful when adjusting the three screws, and the tightening tension is identical for them.

26.4 The Optical Sight

I. Check

1. Mount the instrument on a tripod and fix it.
2. Set a cross mark target which apart from the instrument about 50m.
3. Take the telescope sight the cross mark.
4. Observe the optical sight collimator whether collimating the cross mark, if collimate the mark, adjustment is not necessary; if not, adjust it.

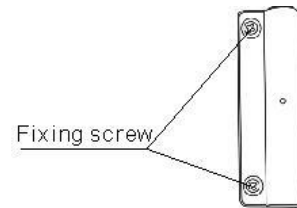

II. Adjustment

1. Mount the instrument at the tripod and fix it.
2. Set a cross mark target which apart from the instrument about 50m.
3. Take the telescope sight the cross mark.
4. Loosen two fixing screws, adjust the collimator, then fix the two screws again.

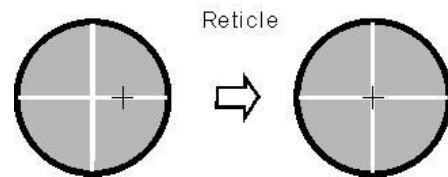

26.5 Optical Plummet (optional)

I. Check

1. Mount the instrument at the tripod and fix it.
2. Set a cross mark under the instrument
3. Coincide the center mark of the optical plummet with the cross mark by adjusting three leveling foot screws.
4. Turn the instrument 180°/200gon, check the center mark and cross mark, if they are coincide, no adjustment is necessary, if not, adjust it.

II. Adjustment

1. Set the instrument on stable device and fix it.
2. Set a cross mark under the instrument.
3. Use the three leveling screws and coincide the center mark of plummet and cross mark on the ground.
4. Rotate the instrument 180°/200gon around and take off the cover of the optical plummet eyepiece, adjust the four adjusting screws with the adjusting pin to shift the center mark to the cross mark, correct only one-half of the displacement in this manner.
- (5) Repeat the operation in (3) and (4) until coincide the center mark of the plummet and cross mark on the ground.

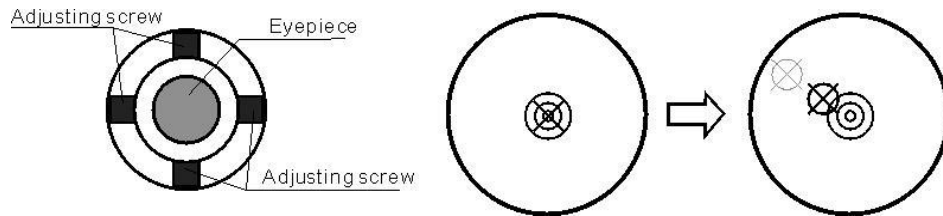

NOTE: When adjust the screws of plummet reticle, firstly loosen the screw on the moving direction of reticle, secondly tighten another screw by the same mount, clockwise turning is for tightening, and anticlockwise turning is for loosening, the turning mount for tightening or loosening should be same.

26.6 Laser Plummet

I. Check

- (1) Set the instrument on stable device and fix it;
- (2) Set a cross mark on the ground under the instrument;
- (3) Turn the three leveling screws until the instrument keeps leveling and the laser spot coincides with the cross mark on the ground;
- (4) Rotate the instrument 180° (200gon) around and check the laser spot and cross mark, if they are coincide, adjustment is not required. Otherwise, adjust it.

II. Adjustment

- (1) Set the instrument on stable device and fix it;
- (2) Set a cross mark on the ground under the instrument;
- (3) Turn the three leveling screws until the instrument keeps leveling and the laser spot coincides with the cross mark on the ground;
- (4) Rotate the instrument 180° (200gon) around and take off the protecting cover of the laser plummet, adjust the four adjusting screws with the screwdriver to move the laser spot to the cross mark, correct only one-half of the displacement in this manner.
- (5) Repeat operation 3, 4 until the instrument keeps leveling and the laser spot coincides with the cross mark when rotating alidade of instrument to any direction.

26.7 Vertical Cross-hair on Telescope

I. Check

- (1) Set the instrument up the tripod and carefully level it.
- (2) Set a point A front the instrument 50m apart;

(3) Collimate the point A and adjust the vertical tangent screw; If the point appears to move continuously on the hair, adjustment is not required. Otherwise, adjust it.

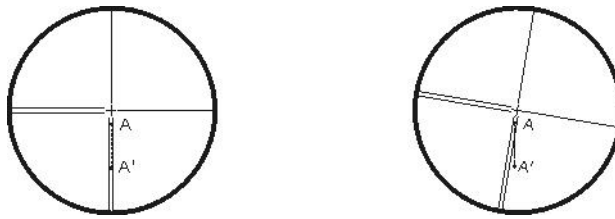

II. Adjustment

- (1) Set the instrument, and set the point A front the instrument 50m apart.
- (2) Take off cover of telescope eyepiece, there are 4 screws for the reticle part.
- (3) Loosen all four fixing screws slightly with the cross screw-driver.
- (4) Revolve the eyepiece section so that the vertical cross-hair coincides to point A, finally, re-tighten the four screws.
- (5) Repeat the checking and adjusting until there is no deviation.

NOTE: After the adjustment of cross-hair, please check the collimation error and vertical index error, see “§27.11 EDM Optical Axis and the Telescope Sighting Axis Error”.

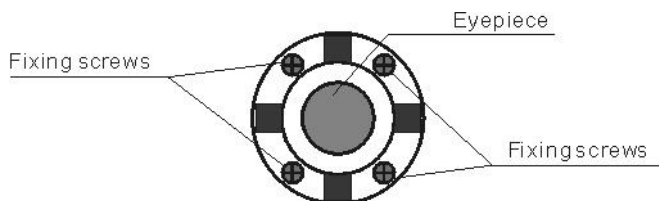

26.8 Horizontal Collimation Error C

If the telescope's sight line isn't perpendicular to the horizontal axis, the collimation error will appear. The assembling, transportation and operation will cause this error.

I. Check

- (1) Set-up the instrument on tripod or adjustment platform and leveling accurately.
- (2) Aim at the cross-hairs of collimator or the obvious target at a distance. Gets the face left angle reading H1 and the face right angle reading Hr.
- (3) Calculating the horizontal collimation error C according to $C = (H1 - Hr \pm 180^\circ) / 2$, if $C < 8''$, no adjustment will be necessary. If $C > 8''$, proceed with the following adjustment.

II. Adjustment

- (1) Power on the instrument after leveling-up, and rotate telescope to initial.
- (2) Aim at the cross-hairs of collimator or the obvious target at a distance. Gets the face left angle reading H1 and the face right angle reading Hr.
- (3) Rotate the instrument in face right position, turning horizontal tangent screw until $Hr' = Hr + C$.
- (4) Loosen the shield of telescope's reticle. Adjusting two screws at left and at right until the vertical hairs of telescope's reticle coincides with the cross-hairs of collimator or target.
- (5) Repeat the check and adjustment procedure until the error is accepted.

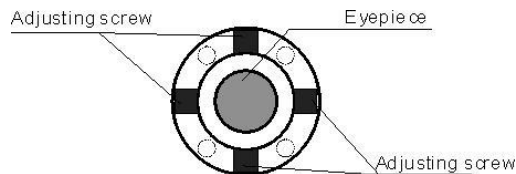

NOTE:

1. When adjusting the screws of reticle, firstly loosen the screw on the moving direction of reticle, secondly tighten another screw by the same amount, clockwise turning is for tightening, and anticlockwise turning is for loosening, the turning amount for tightening or loosening should be same.
2. After the reticle adjustment, it is necessary to adjust the vertical index error by program, see "§23.10 Vertical Index Error".

26.9 Tilt Sensor

If the tilt angle shown on the display shifts from tilt angle 0°(zero point), the instrument is not correctly leveled. This will adversely affect angle measurement. Perform the following procedures to cancel the tilt zero point error.

I. Check

Set-up the instrument on tripod or adjustment platform, and level it accurately.

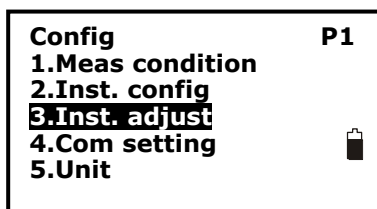

1. Press F4: [OSET] twice to set HA to 0° on P1 in measure mode.
Press ESC then press F4: [CNFG] to enter into config mode.
2. Select "3.Inst adjust" to set instrument basic parameters, two items display.

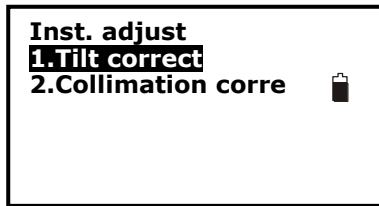

3. Select "1. Tilt correct".

4. Wait a few seconds for this display to stabilize, then read the automatically compensated angles X1 and Y1.

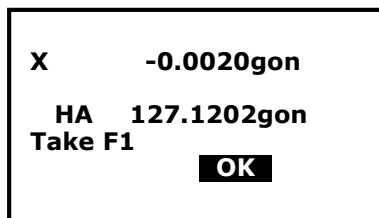

5. Rotate the instrument 180°/200gon. Loosen the horizontal clamp and turn the instrument 180°/200gon while referring to the displayed horizontal angle, then tighten the clamp. Wait a few seconds for the display to stabilize, then read the automatically compensated angles X2 and Y2.

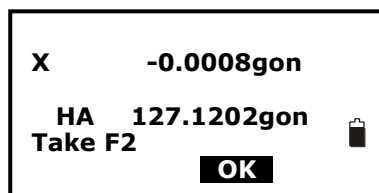

Calculate the following offset values (tilt zero point error):

$$X_{\text{offset}} = (X1 + X2) / 2$$

$$Y_{\text{offset}} = (Y1 + Y2) / 2$$

When the offset value falls within the range $\pm 20''$, adjustment is not necessary. If one of the offset values (X_{offset} , Y_{offset}) exceeds $\pm 20''$, adjust the value as follows.

II. Adjustment

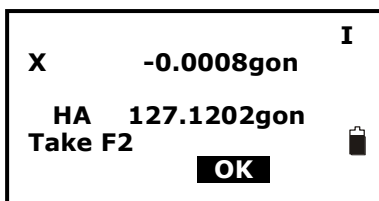

6. Press F3: [OK] to set the horizontal angle to 0°, "Take F2" is displayed.

7. Rotate the top of instrument 180°/200gon. Wait a few seconds for the display to stabilize, then press F3: [OK].

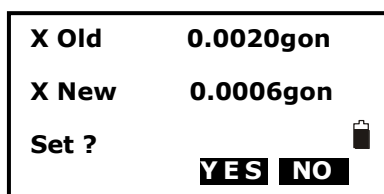

8. If both correction constant are in the range, press F3: [YES] to renew the correction angle, or press F4: [NO] to give up this adjustment,

26.10 Vertical Index Error

The deviation between vertical circle zero position and horizontal direction is vertical index (i), it is necessary to concern this error when measure vertical angle. The instrument program applied a formula to correct this error.

Warning: Before starting this operation, be sure to read this manual carefully, otherwise it may cause data faulty.

Because of the close relationship between vertical index and compensator zero position, it is necessary to check and adjust compensator zero position before adjusting vertical circle, the value should be stable when reading.

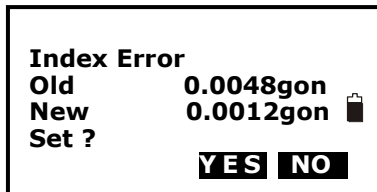

I. Check:
 Please adjust the reticle of telescope and correct the collimation error before this operation.

(1) Mount the instrument at the tripod or a stable device and level it accurately, then turn on the instrument.

(2) Aim at the cross-hairs of collimator or the obvious target at a distance, VA should be about ±10°. Read the face left angle VI and face right angle Vr.

(3) Calculate the index error according to the formula below:

$$i = (VI + Vr - 360^\circ) / 2$$

(4) If $|i| < 10''$, no adjustment is necessary, or you have to adjust it.

II. Adjustment by program:

Set-up the instrument on tripod or adjustment platform, and level it accurately.

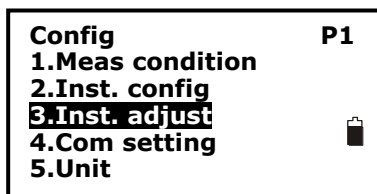

1. press F4: [CNFG] to enter into config mode.

2. Select "3.Inst adjust" to set instrument basic parameters. Two items display.

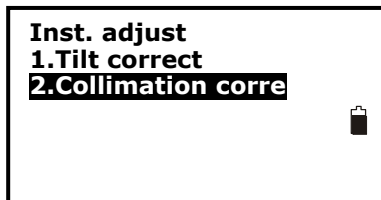

3. Select "2.Index error correct".

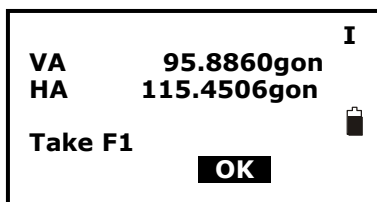

4. Sight a reference point in face I and press F3: [OK].

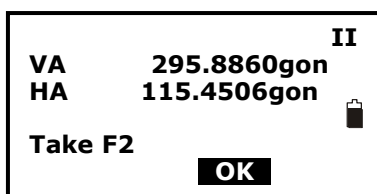

5. Sight the reference point in face II. Rotate the instrument 180°/200gon and sight the same point, then press F3: [OK].

6. Press F3: **[YES]** to set the correction, and press F4: **[NO]** to give up.

26.11 EDM Optical Axis and the Telescope Sighting Axis Error

It is necessary to check this error after the adjustment of telescope reticle error.

I. Check (For R1 series)

- (1) Install the instrument at the tripod or a stable device and level it accurately, then turn on the instrument's power on.
- (2) Set a prism about 2m far away from the instrument.
- (3) Aim at the prism center with telescope reticle
- (4) Enter EDM signal testing screen, see "§4.7 Setting Mode".
- (5) Observe through eyepiece, turn the focusing knob until the read mark is clear, if the deviation between mark and cross-hair is not over 1/5 of red mark diameter, adjustment is unnecessary.

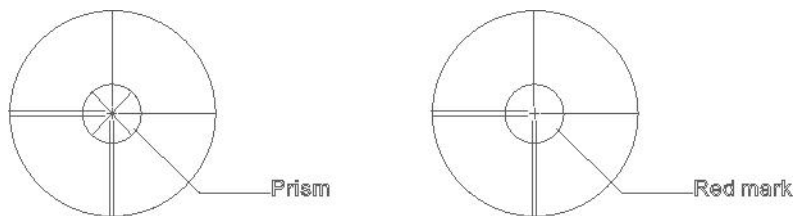

II. Check (For R1 series)

- (1) Install the instrument at the tripod or a stable device and level it accurately, then power on the instrument.
- (2) Set a reflective sheet about 5m-20m far away from the instrument.
- (3) Aim at the sheet cross-mark with telescope reticle.



- (4) Enter EDM signal testing screen, see “§4.7 Setting Mode”.
- (5) Observe the laser spot, if the laser spot coincides with the cross-mark of reflective sheet, adjustment is unnecessary.

NOTE:

1. Laser radiation—Avoid direct eye exposure.
2. If the instrument needs adjustment, please contact your local dealer.

27. Technical Data

R1 series

Telescope

Length	156mm
Image	Erect
Objective aperture	Φ45mm
Magnification	30×
Field of view	1°30'
Mini focus distance	1.0m
Reticle illumination	10 brightness levels

Angle measurement

Reading system	Absolute encoder for R1 series
Circle diameter	79mm
Angle unit	degree/gon, selectable
Minimum display	1"/5"/10", selectable
	0.2mgon/1mgon/2mgon, selectable
Detecting mode	Both circles adopt diametrical detection
Accuracy	2"/5"

Distance measurement

Laser wave length	650-690nm
Laser class	
Reflectorless	Class 3R (IEC 60825-1)
Reflective sheet	Class 3R (IEC 60825-1)
Prism	Class 1(IEC 60825-1)
Measurement range (Overcast, no haze, visibility about 30 km; no heat shimmer)	
Reflectorless ^{*1}	
R300	1 to 300m
R500	1 to 500m
Single prism	1 to 3000m/Class 1
	1000~7000m/Class 3R
Reflective sheet/RP60	1 to 800m
Accuracy	
Prism mode	2mm+2ppm(optional)
Reflective sheet/RP60	3mm+2ppm
Reflectorless mode	
R300	3mm+2ppm(1-150m)/5mm+3ppm(≥150m)
R500	3mm+2ppm(1-200m)/5mm+3ppm(≥200m)

Measurement time(Initial:2.5s)	
Prism	typical 1.0-1.5s,
Reflective sheet(RP60)	typical 1.5s
Reflectorless	typical 1.5-5s, max. 20s
Display resolution(m/inch selectable)	0.2mm/1mm
Temperature unit	°C/°F, selectable
Pressure unit	hPa/mmHg/inchHg, selectable
Temperature input range	-40°C to +60°C (1°C steps)
Pressure input range	500hPa to 1500hPa(1hPa setps)
Prism constant condition	-99.9mm to +99.9mm
Refraction and earth curvature correction	OFF/0.14/0.2, selectable
Reflecting prism constant correction	-99.9mm to +99.9mm

Level vial sensitivity

Plate level	30" / 2mm
Circular level	8' / 2mm

Compensation

System	Dual-axis (FOR R1 PLUS ONLY)
Range	Liquid type
Setting accuracy	±3'
	1"

Compensation

System	Single-axis (FOR R1-5 300)
Range	Liquid type
Setting accuracy	±3'
	1"

Laser plummet*2

Accuracy	±1mm/1.5m
Laser class	Class 2/IEC60825-1
Laser wave length	635nm

Display

LCD	6lines×20 characters (96 x160 dots)
-----	-------------------------------------

Memory

Internal memory	128M
External SD card	standard

Data communication

I/O	RS-232C/USB/SD card
-----	---------------------

Power

Battery	3400mAh Li-ion Rechargeable battery
Voltage	7.4V DC
Continuous operation time	Approx. 26 hours(At +20°C, single distance measurement every 30s)
Chargers	FDJ6-Li(100V to 240V)
Charging time	Approx. 4 hours

Others

CPU	32-bit
EDM technology	Digital signal processing
Working temperature	-20°~+50°C
Dimension	175×178×340mm(W×D×H)
Weight	5.1kg
Water and dust protection	IP66 (IEC60529)

*1 **Technical Data for R1 Power series EDM Reflectorless Measurement Range**

Option	Kodak Gray Card	Range D	Range E	Range F
		m	m	m
R300	White side, 90% reflective	200	250	300
	Gray side, 18% reflective	100	120	150
R500	White side, 90% reflective	300	400	500
	Gray side, 18% reflective	150	200	250

**Atmospheric
Conditions**

D: Object in strong sunlight, severe heat shimmer
 E: Object in shade, sky overcast
 F: Underground, night and twilight

*2 Laser plummet mounted on the bottom of the vertical axis

28. Accessories

• Carrying case	1 pcs
• Battery	2 pcs
• Charger	1 pcs
• Adjusting pins	2 pcs
• Screwdriver	1 pcs
• Wrench	1 pcs
• Silica gel	1 pcs
• Certification	1 pcs
• Packing list	1 pcs
• Instruction manual	1 pcs
• CD-ROM	1 pcs
• Communication cable	1 pcs
• Reflective sheet/RP30	4 pcs (only for R1 series)
• Reflective sheet/RP60	1 pcs (only for R1 series)
• Laser caution sign board	1 pcs (only for R1 series)

Appendix I: Atmospheric correction formula and chart (Just for reference)

Factory setting: temperature: 20°C, pressure: 1013hPa, 0ppm

The correction:

$$K_{pt} = 274.417 - 0.2905 * p / (1 + 0.0036 * t) \dots\dots\dots$$

$$K_{pt} = 278.960 - 0.2902 * p / (1 + 0.0036 * t) \dots\dots\dots$$

Where: p--Pressure value (hPa)

t--Temperature value (°C)

K_{pt}--Atmospheric correction (ppm)

Example:

t=20°C, p=1013hpa, L0=1000m.

Then: K_{pt}=0ppm

K_{pt}=4ppm

$$L = L_0(1 + K_{pt}) = 1000 \times (1 + 0 \times 10^{-6}) = 1000.000m$$

$$L = L_0(1 + K_{pt}) = 1000 \times (1 + 4 \times 10^{-6}) = 1000.004m$$

The atmospheric value is obtained easily with the atmospheric correction chart. Find the measured temperature in horizontal axis, and pressure in vertical axis on the chart. Read the value from the diagonal line, which is the required atmospheric correction value.

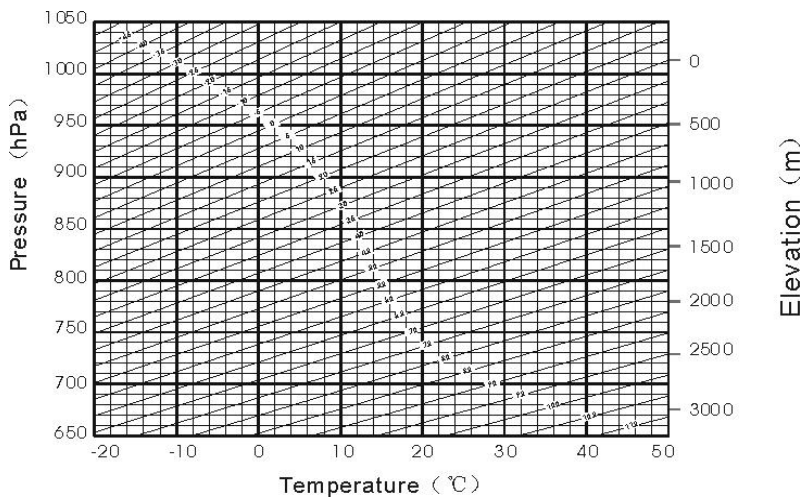

For R1 series

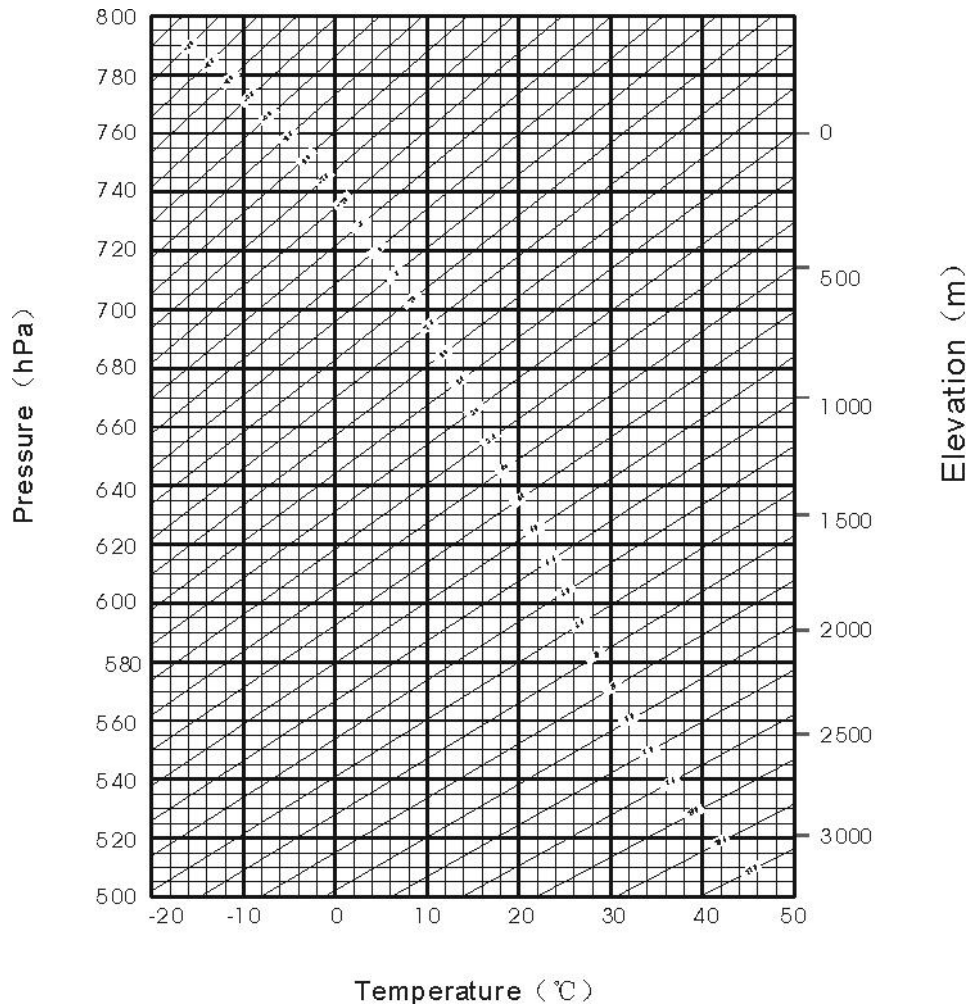

For R1 series

Appendix II: Correction for refraction and earth

curvature

Considering the correction of refraction and earth curvature for distance measurement, the formula for slope distance, horizontal distance and vertical distance applied in the instrument are as followings:

$$SD = D_0 \times (1 + ppm \times 10^{-6}) + mm$$

- SD — Displayed slope distance (m)
 D₀ — Real measured distance (m)
 ppm — Scale coefficient (mm/km)
 mm — Target constant (mm)

$$HD = Y - A \times X \times Y$$

$$VD = X + B \times Y^2$$

- HD — Horizontal distance (mm)
 VD — Vertical distance (mm)
 Y = SD · |Sin ξ|
 X = SD · Cos ξ
 ξ — Zenith angle

$$A = \frac{1 - \frac{K}{2}}{R}$$

$$B = \frac{1 - \frac{K}{2}}{2R}$$

$$K = 0.142 \text{ or } 0.20$$

$$R = 6.37 \times 10^6 \text{ (m)}$$

The conversion formula for horizontal and vertical distance is as follows when correction for refraction and earth curvature is not applied:

$$HD = SD \cos \xi \quad VD = SD |\sin \xi|$$

NOTE:

The factory setting for the refraction coefficient K is 0.142.
 Refer to the “§3.8.1 Measure Condition Setting” to change the value.

NOTE:

These designs, figures and specifications are subject to change without notice. We shall not be held liable for damages resulting from errors in this instruction manual.

Appendix III: STANDARD LIMITED WARRANTY

General Warranty for Instruments.

The terms and conditions of this Limited Warranty constitute the complete and exclusive warranty agreement between The Customer or Dealer and STONEX® for the Product and it supersedes any prior agreement or representation made in any STONEX® sales document or advice that may be provided to Customer by any STONEX® representative in connection with Customer's purchase of the Product. No change to the conditions of this Limited Warranty is valid unless it is made in written form and signed by an authorized STONEX® supervisor.

STONEX® warrants that its Products:

1. are free from defects in materials or workmanship for generally 1/2 year except for accessories or specific parts for which different limited warranty period shall apply .
2. have been tested/calibrated in proper working status prior to shipment.

The warranty period starts from date of first sale of the instruments. At its sole discretion, under the warranty period, STONEX® will repair the product or send parts for replacement at its expense. STONEX® agree to repair or replace the defected instrument within thirty (30) days, only if STONEX® recognizes that the defects of the instrument are not caused by human factors or no obvious damage to its surface is visible. STONEX® warrants any new replaced parts or products are warranted to be free from defects in materials and workmanship for thirty (30) days or for the remainder of the Limited Warranty Period of the Product in which they are installed, whichever is longer. Faulty Parts or Products replaced under this Limited Warranty shall become property of STONEX®.

All products that have to be repaired have to be returned to our technical representative office location via any delivery company the customer prefers.

NOTE:

STONEX® is not accountable for the unlikely event that the Products gets lost in transit. Any damage inflicted by the customer or by third party after the products has been delivered to the customer is excluded from the limited warranty as well any damage arising from an improper use, from any action or use not provided for in the enclosed user guides and/or manuals.

Shipping policy

The Customer or the dealer is required to pay for the charges for shipping of fault

parts or instruments to STONEX® representative office and STONEX® (will provide) the shipping for return. Dealers needs to follow STONEX® repair/service procedure (see appendix 4) to achieve a better and prompt service result.

Return policy Dead On Arrival instruments

All returned products have to be shipped to STONEX® representative office. The original Purchaser has a period of seven (7) days, starting from date (data) of purchasing to signal the existence of a defect in the instrument for a full refund (less shipping and handling), provided the merchandise is in new, resalable condition and returned in the original, undamaged packaging. Customer has to pay for both the return and the original freight fees, regardless of the original freight paid by the Company. All warranty books, instruction manuals, parts and accessories must be included as well as the original box in which the item was shipped. We recommend to place the original carton inside another box, to avoid any additional damage to the carton itself. In some cases, returns of special items will require a re-stock fee . Acceptance of returned merchandise is final only after inspection by STONEX®.

Above terms and (policy shall apply as for hardware.) Dealers needs to follow STONEX® repair/service procedure (see appendix 4) to achieve a better and prompt service result.

Firmware/Software warranty.

Stonex doesn't warrant that operation of Firmware/Software on any instruments will be uninterrupted or error-free, or that functions contained in Firmware/Software will operate to meet your requirements.

Stonex will forward the Software/Firmware Fix to the dealer or customer. Firmware/software Fix means an error correction or other update created to fix a previous firmware version that substantially doesn't conform to the instruments specification.

Over Warranty repair(s) policy.

Customer shall pay the standard repair fees for any service (whether part replacement or repairs) and performed by STONEX® under request and explicit authorization of the customer itself. In this case the customer is charged for return shipment's fees as well.

Disclaimer and Limitation of Remedy.

All other express and implied warranties for this product, including the implied warranties of merchantability and fitness for a particular purpose and/or

noninfringement of any third party's rights, are hereby disclaimed. Stonex® expressly disclaims all warranties not stated in this limited warranty. any implied warranties that may be imposed by law are limited in duration to the term of this limited warranty. Some jurisdictions do not allow the exclusion of implied warranties or limitations on how long an implied warranty lasts, so the above exclusions or limitations may not apply to customer. Customer must read and follow all set-up and usage instructions in the applicable user guides and/or manuals enclosed. if customer fails to do so, this product may not function properly and may be damaged. Customer may lose data or sustain personal injuries. Stonex®, its affiliates and suppliers do not warrant that operation of this product will be uninterrupted or error free; as do all electronics at times. If this product fails to work as warranted above, customer's sole and exclusive remedy shall be repair or replacement. in no event will Stonex®, its affiliates or suppliers be liable to customer or any third party for any damage in excess of the purchase price of the product. this limitation applies to damages of any kind whatsoever including (1) damage to, or loss or corruption of, customer's records, programs, data or removable storage media, or (2) any direct or indirect damages, lost profits, lost savings or other special, incidental, exemplary or consequential damages, whether for breach of warranty, contract, tort or otherwise, or whether arising out of the use of or inability to use the product and/or the enclosed user guides and/or manuals, even if Stonex®, or an authorized Stonex® representative, authorized service provider or reseller has been advised of the possibility of such damages or of any claim by any other party. Some jurisdictions do not allow the exclusion or limitation of incidental or consequential damages for some products, so the exclusions or limitations may not apply to customer. This limited warranty gives customer specific legal rights, and customer may also have other rights which vary from country/state/jurisdiction to country/state.

Two (2) years on STONEX® Product:

Total Station R1/R1 Plus (all variants) excluding battery and power supply accessories (6 months).

Repair/Service procedure for dealers.

- (1) S/N of the instrument and a detailed description of the defect (sometimes pictures or video) will be required to indicate the cause and problem.
- (2) If dealer wants to repair an instrument under warranty period on their site:
 - 1) If dealers (don't) have the part in stock they have to send an official order to STONEX® and pay for it and then so STONEX® will send the new part to them so they can repair the instrument.

2) When the repair is over dealer has to fill the "Spare Part Refund" module and send it to the dedicated mail address.

3) wait for STONEX®'s authorization SPR no;

4) when dealer receives the SPR authorization number they can send back to STONEX® appointed office the broken part with attached the SPR module;

5) when STONEX® receive the broken part STONEX® shall verify it and if everything is ok the cost of the part shall be refund (refund will be done only after check of the failure part and final approval of STONEX®).

(3) If the instrument needs to be sent back to STONEX® for repair/replacement, dealers/customers has to send to STONEX® a "Returned Merchandise Authorization (RMA)" before they send back the fault instrument. STONEX® shall, at its sole discretion, decide on the place of performance for work under warranty.

Appendix IV: FCC Statements

Total Station R1Plus:

This device complies with part 15 of the FCC Rules. Operation is subject to the following two conditions:

- (1) This device may not cause harmful interference.
- (2) this device must accept any interference received, including interference that may cause undesired operation.

Power adapter model FDJ6-Li:

This device complies with part 15 of the FCC Rules. Operation is subject to the following two conditions:

- (1)This device may not cause harmful interference.
- (2) This device must accept any interference received, including interference that may cause undesired operation.

Appendix V: Environmental recycling

The cardboard box, the plastic in the package and the various parts of this product have to be recycled and disposed of in accordance with the current legislation of your Country.

FOR COUNTRIES IN THE EUROPEAN UNION (EU)

The disposal of electric and electronic device as solid urban waste is strictly prohibited: they must be collected separately.

Contact Local Authorities to obtain practical information about correct handling of the waste, location and times of waste collection centres. When you buy a new device of ours, you can give back to our dealer a used similar device.

The dumping of these devices at unequipped or unauthorized places may have hazardous effects on health and environment.

The crossed dustbin symbol means that the device must be taken to authorized collection centers and must be handled separately from solid urban waste.



FOR COUNTRIES OUTSIDE EUROPEAN UNION (EU)

The treatment, recycling, collection and disposal of electric and electronic devices may vary in accordance with the laws in force in the Country in question.



STONEX® SRL

Via Cimabue, 39 - 20851 Lissone (MB)

Tel : +390392783008 ; +390392785575 | Fax :+390392789576

www.stonexpositioning.com | info@stonexpositioning.com